

6W isolated DC-DC converter  
Ultra-wide input voltage and regulated dual/single output

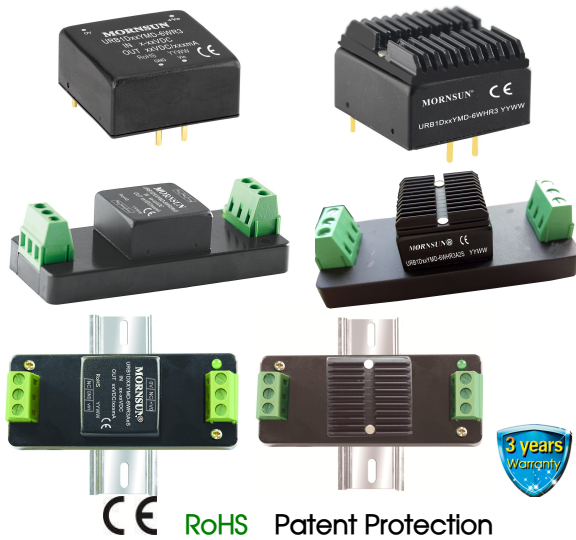

### FEATURES

- Ultra-wide 4:1 input voltage range
- High efficiency up to 86%
- I/O isolation test voltage: 2.25k VDC
- Operating ambient temperature range: -40°C to +85°C
- Input under-voltage protection, output short-circuit, over-current, over-voltage protection
- Low ripple & noise
- Input reverse polarity protection available with chassis(A2S ) or Din-Rail mounting (A4S) version
- EN62368 approved
- Meets EN50155 railway standard
- Industry standard pin-out

URA1D\_YMD-6WR3 & URB1D\_YMD-6WR3 series of isolated 6W DC-DC converter with 40-160VDC input voltage with efficiencies of up to 86%, input to output isolation is tested with 2250VDC and the converter safely operate ambient temperature of -40°C to +85°C, input under-voltage protection, output short-circuit, over-current, over-voltage protection. They are widely used in railway vehicle applications using 72V, 96V and 110V battery voltages.

### Selection Guide

Certification	Part No. ①	Input Voltage (VDC)		Output		Full Load Efficiency ④ (%) Min./Typ.	Capacitive Load (μF)Max.
		Nominal ② (Range)	Max. ③	Voltage (VDC)	Current (mA) Max./Min.		
CE	URA1D05YMD-6WR3	110 (40-160)	170	±5	±600/0	78/80	470
	URA1D12YMD-6WR3			±12	±250/0	82/84	100
	URA1D15YMD-6WR3			±15	±200/0	83/85	100
	URB1D05YMD-6WR3			5	1200/0	78/80	1000
	URB1D12YMD-6WR3			12	500/0	82/84	470
	URB1D15YMD-6WR3			15	400/0	83/85	220
	URB1D24YMD-6WR3			24	250/0	84/86	100

Note:  
 ① Use "H" suffix for heat sink mounting, "A2S" suffix for chassis mounting and "A4S" suffix for Din-Rail mounting. We recommend to choose modules with a heat sink for enhanced heat dissipation and applications with extreme temperature requirements;  
 ② The minimum input voltage and starting voltage of A2S and A4S Model are 1VDC higher than those of DIP package due to input reverse polarity protection function;  
 ③ Exceeding the maximum input voltage may cause permanent damage;  
 ④ Efficiency is measure at nominal input voltage and rated output load; efficiencies for A2S and A4S Model's is decreased by 2% due to the input reverse polarity protection circuit.

### Input Specifications

Item	Operating Conditions	Min.	Typ.	Max.	Unit
Input Current (full load / no-load)	Nominal input voltage	--	68/3	70/8	mA
Reflected Ripple Current	Nominal input voltage	--	25	--	
Surge Voltage (1sec. max.)		-0.7	--	180	VDC
Start-up Voltage		--	--	40	
Input Under-voltage Protection		28	33	--	
Start-up Time	Nominal input voltage & constant resistance load	--	10	--	ms
Input Filter		Pi filter			
Hot Plug		Unavailable			
Ctrl*	Module on	Ctrl pin open or pulled high (3.5-12VDC)			
	Module off	Ctrl pin pulled low to GND (0-1.2VDC)			
	Input current when off	--	3	8	mA

Note: \*The Ctrl pin voltage is referenced to input GND.

### Output Specifications

Item	Operating Conditions	Min.	Typ.	Max.	Unit
Voltage Accuracy <sup>①</sup>	0%-100% load	--	±1	±3	%
Linear Regulation	Input voltage variation from low to high at full load	Vo1	±0.2	±0.5	
		Vo2	±0.5	±1	
Load Regulation <sup>②</sup>	0%-100% load	URB1D_YMD-6WR3	±0.5	±1	
	5%-100% load	Vo1 of URA1D_YMD-6WR3	±0.5	±1	
		Vo2 of URA1D_YMD-6WR3	±0.5	±1.5	
Cross Regulation	Dual outputs, Vo1 load at 50%, Vo2 load at range of 25%-100%	--	--	±10	
Transient Recovery Time		--	300	500	μs
Transient Response Deviation	25% load step change, nominal input voltage	5V, ±5V output	±3	±8	%
		Others	±3	±5	
Temperature Coefficient	Full load	--	±0.02	±0.03	%/°C
Ripple & Noise <sup>③</sup>	20MHz bandwidth, 5%-100% load	--	50	100	mVp-p
Over-voltage Protection	Input voltage range	110	--	160	%Vo
Over-current Protection		120	--	210	%Io
Short-circuit Protection		Continuous, self-recovery			

Note:  
 ①Vo2 output voltage accuracy of ±5VDC output converter for 0%-5% load is ±5% max;  
 ②URA1D\_YMD-6WR3 load regulation for 0%-100% load is ±5%;  
 ③Ripple & Noise at ≤ 5% load is 5%Vo Max. The "parallel cable" method is used for ripple and noise test, please refer to *DC-DC Converter Application Notes* for specific information.

### General Specifications

Item	Operating Conditions	Min.	Typ.	Max.	Unit
Isolation	Input-output Electric Strength Test for 1 minute with a leakage current of 1mA max.	2250	--	--	VDC
	Input/output-case Electric Strength Test for 1 minute with a leakage current of 1mA max.	1600	--	--	
Insulation Resistance	Input-output resistance at 500VDC	1000	--	--	MΩ
Isolation Capacitance	Input-output capacitance at 100kHz/0.1V	--	1000	--	pF
Operating Temperature	See Fig.1	-40	--	+85	°C
Storage Temperature		-55	--	+125	
Pin Soldering Resistance Temperature	Soldering spot is 1.5mm away from case for 10 seconds	--	--	+300	
Storage Humidity	Non-condensing	5	--	95	%RH
Vibration		IEC61373 - Category 1, Grade B			
Switching Frequency *	PWM Mode	--	300	--	kHz
MTBF	MIL-HDBK-217F@25°C	1000	--	--	k hours

Note:\*Switching frequency is measured at full load. The module reduces the switching frequency for light load (below 50%) efficiency improvement.

### Mechanical Specifications

Case Material	Aluminum alloy				
Dimensions	Horizontal package( without heat sink)			25.40 x 25.40 x 11.70 mm	
	Horizontal package( with heat sink)			25.40 x 25.40 x 16.20 mm	
	A2S wiring package ( without heat sink)			76.00 x 31.50 x 21.20 mm	
	A2S wiring package( with heat sink)			76.00 x 31.50 x 25.20 mm	
	A4S rail package( without heat sink)			76.00 x 31.50 x 25.80 mm	
	A4S rail package( with heat sink)			76.00 x 31.50 x 29.80 mm	
Weight	Without heat sink	Horizontal package/A2S wiring package/A4S rail package			12.5g/36.0g/56.0g (Typ.)
	With heat sink	Horizontal package/A2S wiring package/A4S rail package			17.0g/40.0g/59.0g (Typ.)
Cooling Methods	Free air convection				

Electromagnetic Compatibility (EMC)

Emissions	CE	CISPR32/EN55032	CLASS B (see Fig.3 or Fig.4-② for recommended circuit)	
	RE	CISPR32/EN55032	CLASS B (see Fig.3 or Fig.4-② for recommended circuit)	
Immunity	ESD	IEC/EN61000-4-2	Contact ±6kV/Air ±8kV perf. Criteria B	
	RS	IEC/EN61000-4-3	20V/m perf. Criteria A	
	EFT	IEC/EN61000-4-4	±4kV(see Fig.3 or Fig.4-① for recommended circuit) perf. Criteria B	
	Surge	IEC/EN61000-4-5	line to line ±2kV (2Ω, 18μF see Fig.3 for recommended circuit) line to ground ±4kV (12Ω, 9μF see Fig.3 for recommended circuit) perf. Criteria B	
	CS	IEC/EN61000-4-6	10 Vr.m.s perf. Criteria A	

Electromagnetic Compatibility (EMC) (EN50155)

Emissions	CE	EN50121-3-2	150kHz-500kHz 99dBμV 500kHz-30MHz 93dBμV
	RE	EN50121-3-2	30MHz-230MHz 40dBμV/m at 10m 230MHz-1GHz 47dBμV/m at 10m
Immunity	ESD	EN50121-3-2	Contact ±6kV/Air ±8kV perf. Criteria B
	RS	EN50121-3-2	20V/m perf. Criteria A
	EFT	EN50121-3-2	±2kV 5/50ns 5kHz perf. Criteria A
	Surge	EN50121-3-2	line to line ±1kV (42Ω, 0.5μF) line to ground ±2kV (42Ω, 0.5μF) perf. Criteria B
	CS	EN50121-3-2	0.15MHz-80MHz 10Vr.m.s perf. Criteria A

Note: All the tests are measured under the conditions of input capacitor 100μF/200V or FC-C01D.

Typical Characteristic Curves

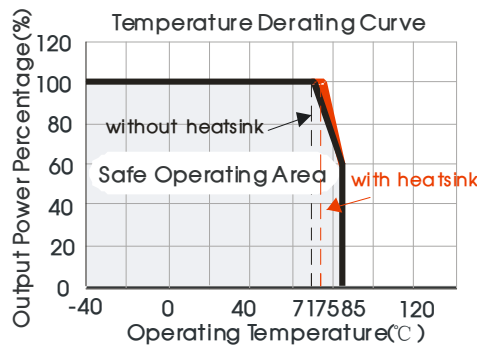
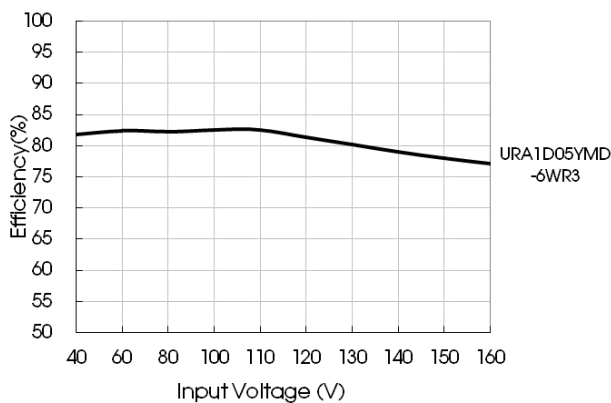
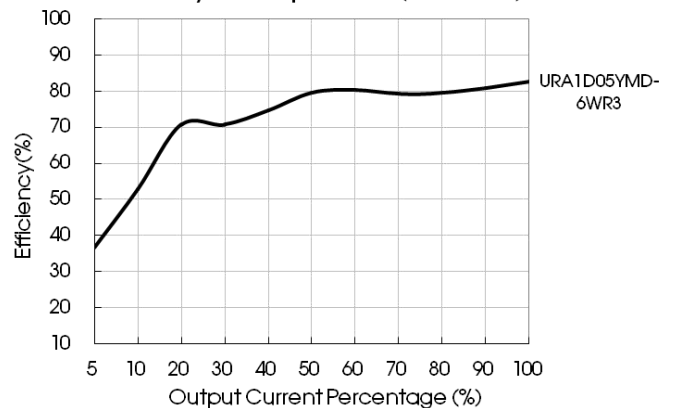

Fig. 1

Efficiency Vs Input Voltage (Full Load)



Efficiency Vs Output Load (Vin=110V)



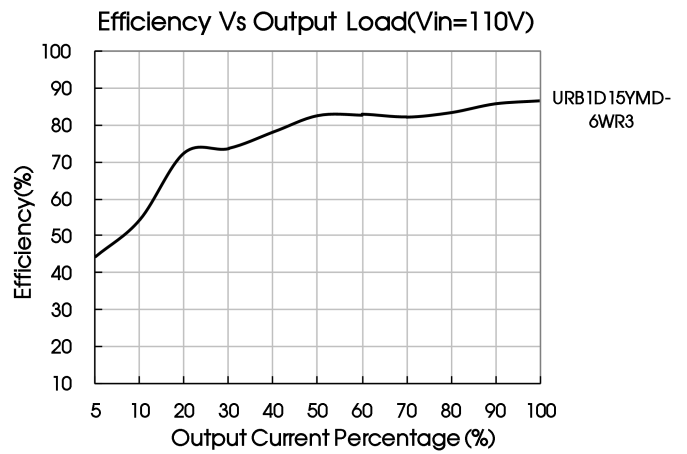
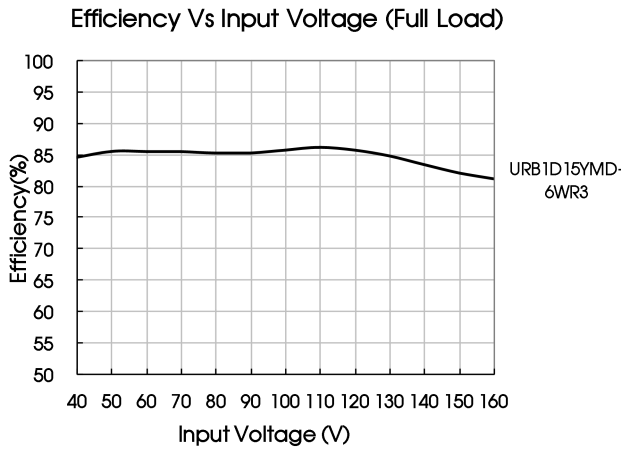

## Design Reference

### 1. Typical application

All the DC/DC converters of this series are tested before delivery using the recommended circuit shown in Fig. 2.

Input and/or output ripple can be further reduced by appropriately increasing the input & output capacitor values  $C_{in}$  and  $C_{out}$  and/or by selecting capacitors with a low ESR (equivalent series resistance). Also make sure that the capacitance is not exceeding the specified max. capacitive load value of the product.

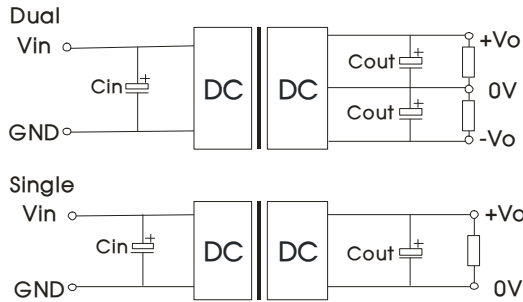

Fig. 2

$C_{in}$	$V_o$ (VDC)	$C_{out}$
10 $\mu$ F/250V -47 $\mu$ F/250V	$\pm 5/5$	10 $\mu$ F/16V
	$\pm 12/12/\pm 15/15$	10 $\mu$ F/25V
	24	10 $\mu$ F/50V

### 2. EMC compliance circuit

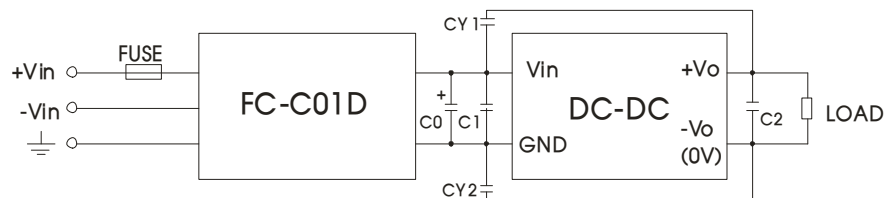

Fig. 3

Fig. 3 Parameter description:

FUSE	Choose according to actual input current
FC-C01D	FC-CX1D is the EMC auxiliary component of our company. Input voltage range: 40V-160V
C0	100 $\mu$ F/200V
C1	Refer to the $C_{in}$ in Fig.2
C2	Refer to the $C_{out}$ in Fig.2
CY1/CY2	1nF/3kV

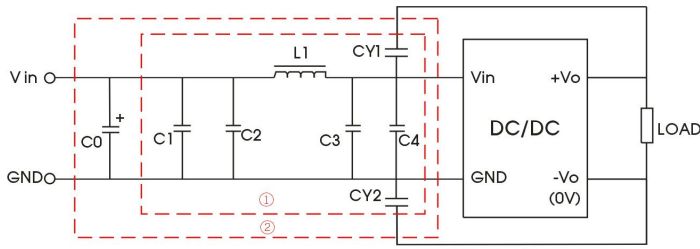

Fig. 4 Parameter description:

C0	100μF/200V
C1/C2/C3/C4	0.22μF/250V
L1	68μH
CY1/CY2	1nF/3kV

Fig. 4

3. The products do not support parallel connection of their output

4. For additional information about Mornsun EMC Filter products please refer to [www.mornsun-power.com](http://www.mornsun-power.com) to download the Selection Guide of EMC Filter

Horizontal Package (without heat sink) Dimensions and Recommended Layout

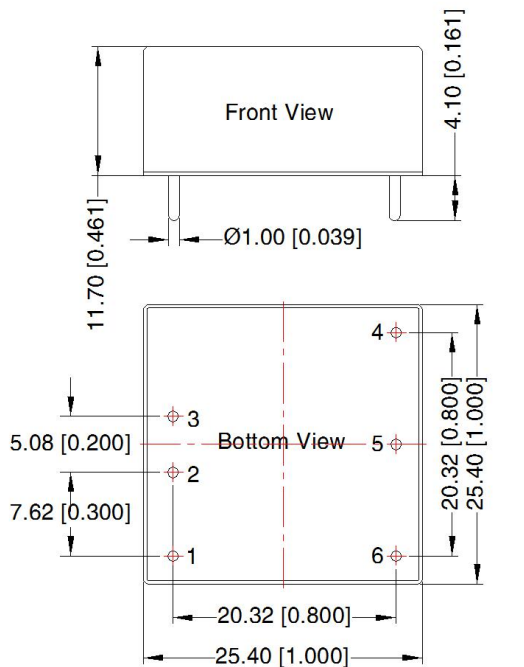

Note:  
 Unit: mm[inch]  
 Pin diameter tolerances: ± 0.10 [± 0.004]  
 General tolerances: ± 0.50 [± 0.020]

THIRD ANGLE PROJECTION

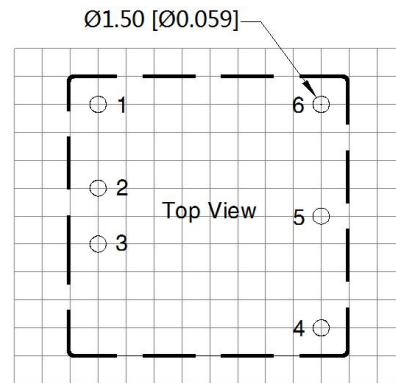

Note: Grid 2.54\*2.54mm

Pin	Pin-Out	
	Single	Dual
1	No pin	Ctrl
2	GND	GND
3	Vin	Vin
4	+Vo	+Vo
5	No pin	0V
6	0V	-Vo



Horizontal Package (with heat sink) Dimensions

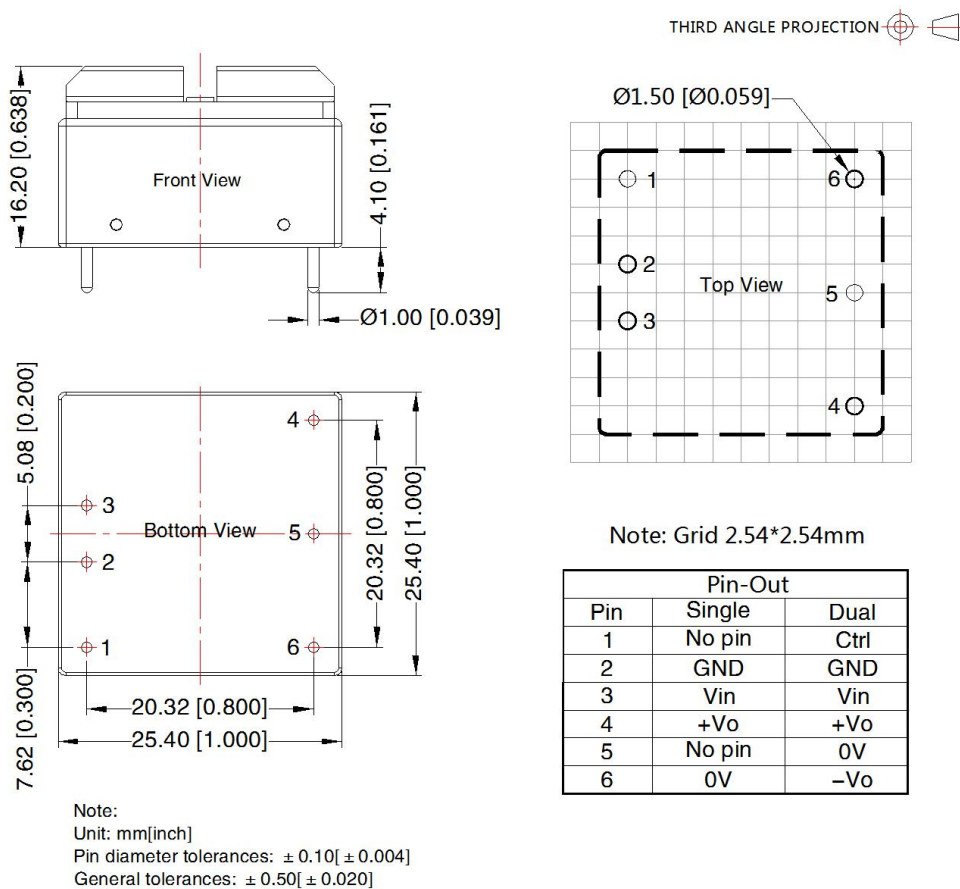

URA1D\_YMD-6WR3A2S & URB1D\_YMD-6WR3A2S (without heat sink) Dimensions

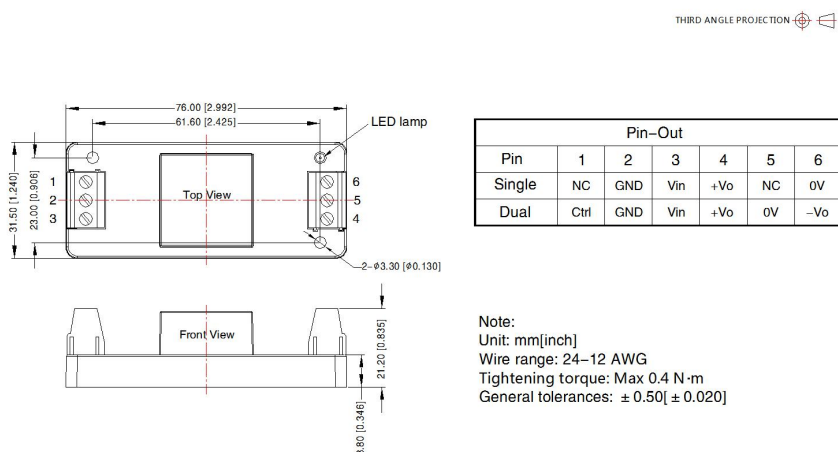

URA1D\_YMD-6WHR3A2S & URB1D\_YMD-6WHR3A2S (with heat sink) Dimensions

THIRD ANGLE PROJECTION 

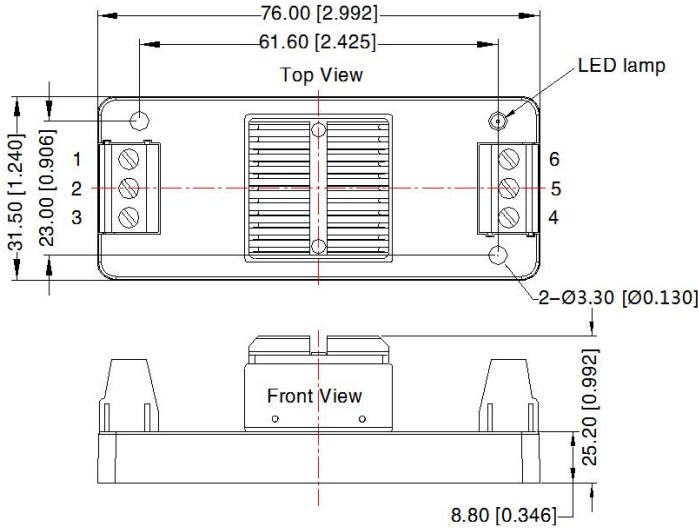

Pin-Out						
Pin	1	2	3	4	5	6
Single	NC	GND	Vin	+Vo	NC	0V
Dual	Ctrl	GND	Vin	+Vo	0V	-Vo

Note:  
 Unit: mm[inch]  
 Wire range: 24-12 AWG  
 Tightening torque: Max 0.4 N · m  
 General tolerances: ± 1.00 [± 0.039]

URA1D\_YMD-6WR3A4S & URB1D\_YMD-6WR3A4S (without heat sink) Dimensions

THIRD ANGLE PROJECTION 

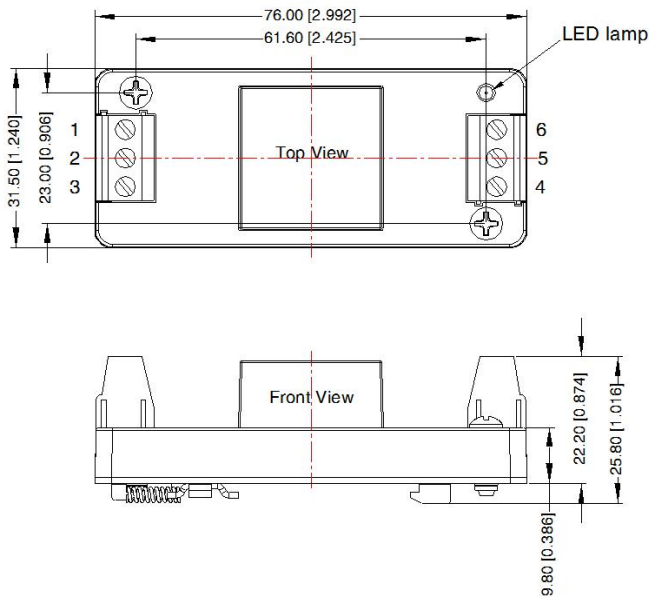

Pin-Out						
Pin	1	2	3	4	5	6
Single	NC	GND	Vin	+Vo	NC	0V
Dual	Ctrl	GND	Vin	+Vo	0V	-Vo

Note:  
 Unit: mm[inch]  
 Mounting rail: TS35  
 Wire range: 24-12 AWG  
 Tightening torque: Max 0.4 N · m  
 General tolerances: ± 1.00 [± 0.039]

URA1D\_YMD-6WHR3A4S & URB1D\_YMD-6WHR3A4S(with heat sink) Dimensions

THIRD ANGLE PROJECTION 

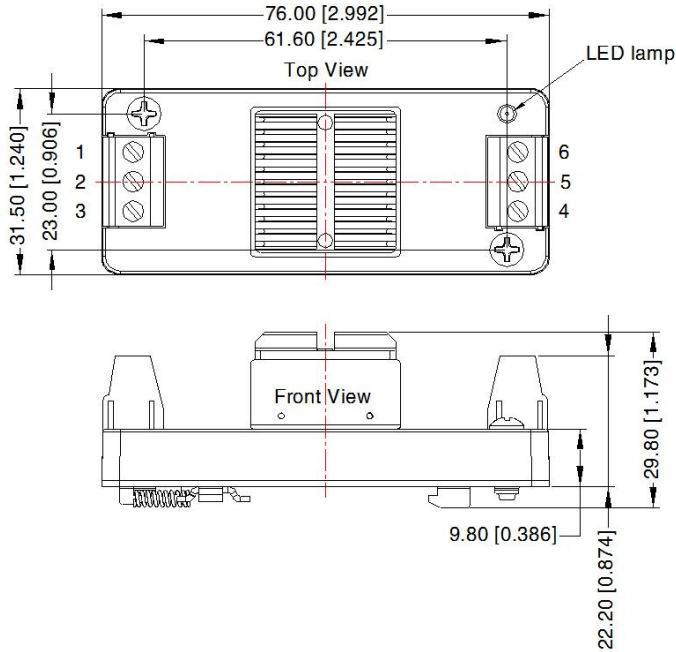

Pin-Out						
Pin	1	2	3	4	5	6
Single	NC	GND	Vin	+Vo	NC	0V
Dual	Ctrl	GND	Vin	+Vo	0V	-Vo

Note:  
Unit: mm[inch]  
Mounting rail: TS35  
Wire range: 24-12 AWG  
Tightening torque: Max 0.4 N · m  
General tolerances: ± 1.00[± 0.039]

- Note:
- For additional information on Product Packaging please refer to [www.mornsun-power.com](http://www.mornsun-power.com). The Packaging bag number of Horizontal package: 58210003(without heat sink), 58200048(with heat sink), A2S/ A4S package number: 58220022;
  - The maximum capacitive load offered were tested at input voltage range and full load;
  - Unless otherwise specified, parameters in this datasheet were measured under the conditions of Ta=25°C, humidity<75%RH with nominal input voltage and rated output load;
  - Other product application information, please see DC-DC (railway power supply) Converter Application Notes for specific operation methods-2016 Edition;
  - All index testing methods in this datasheet are based on company corporate standards;
  - We can provide product customization service, please contact our technicians directly for specific information;
  - Products are related to laws and regulations: see "Features" and "EMC";
  - Our products shall be classified according to ISO14001 and related environmental laws and regulations, and shall be handled by qualified units.

Mornsun Guangzhou Science & Technology Co., Ltd.

Address: No. 5, Kehui St. 1, Kehui Development Center, Science Ave., Guangzhou Science City, Huangpu District, Guangzhou, P. R. China  
Tel: 86-20-38601850 Fax: 86-20-38601272 E-mail: [info@mornsun.cn](mailto:info@mornsun.cn) [www.mornsun-power.com](http://www.mornsun-power.com)