



N31B Hardware Design

GNSS Module Series

Version: V1.1

Date: 2020-06-02

LYNO
CONFIDENTIAL



Notice

Some features of the product and its accessories described herein rely on the software installed, capacities and settings of local network, and therefore may not be activated or may be limited by local network operators or network service providers. Thus, the descriptions herein may not exactly match the product or its accessories which you purchase. Shanghai Mobiletek Communication Ltd reserves the right to change or modify any information or specifications contained in this manual without prior notice and without any liability.

Copyright

This document contains proprietary technical information which is the property of Shanghai Mobiletek Communication Ltd. copying of this document and giving it to others and the using or communication of the contents thereof, are forbidden without express authority. Offenders are liable to the payment of damages. All rights reserved in the event of grant of patent or the registration of a utility model or design. All specification supplied herein are subject to change without notice at any time.

DISCLAIMER

ALL CONTENTS OF THIS MANUAL ARE PROVIDED "AS IS". EXCEPT AS REQUIRED BY APPLICABLE LAWS, NO WARRANTIES OF ANY KIND, EITHER EXPRESS OR IMPLIED, INCLUDING BUT NOT LIMITED TO, THE IMPLIED WARRANTIES OF MERCHANTABILITY AND FITNESS FOR A PARTICULAR PURPOSE, ARE MADE IN RELATION TO THE ACCURACY, RELIABILITY OR CONTENTS OF THIS MANUAL. TO THE MAXIMUM EXTENT PERMITTED BY APPLICABLE LAW, IN NO EVENT SHALL SHANGHAI MOBILETEK COMMUNICATION LTD BE LIABLE FOR ANY SPECIAL, INCIDENTAL, INDIRECT, OR CONSEQUENTIAL DAMAGES, OR LOSS OF PROFITS, BUSINESS, REVENUE, DATA, GOODWILL SAVINGS OR ANTICIPATED SAVINGS REGARDLESS OF WHETHER SUCH LOSSES ARE FORSEEABLE OR NOT.

Version History

Date	Version	Description of change	Author
2018-11-28	V1.0	Initial	Tp.Lin
2020-06-02	V1.1	Add N31B-H Delete Alwayslocate mode	Jason.Liao

Content

1. INTRODUCTION.....	5
2. N31B SERIES OVERVIEW	5
2.1 N31B SERIES FUNCTIONAL DIAGRAM.....	6
2.2 GNSS PERFORMANCE	7
2.3 GENERAL FEATURES.....	10
3. PACKAGE INFORMATION.....	10
3.1 PIN OUT DIAGRAM.....	10
3.2 PIN DESCRIPTION.....	10
3.3 PACKAGE DIMENSIONS	11
3.4 N31B SERIES RECOMMENDED PCB DECAL	12
4. APPLICATION INTERFACE	13
4.1 POWER MANAGEMENT.....	13
4.1.1 <i>Power Input</i>	13
4.1.2 <i>Starting N31B Series</i>	13
4.1.3 <i>Verification of N31B Series Start</i>	13
4.1.4 <i>Power Saving Modes</i>	13
4.1.5 <i>Operating Mode</i>	14
4.2 UART INTERFACE.....	16
4.3 RESET INPUT.....	16
4.4 1PPS OUTPUT.....	17
4.5 A-GPS AND EASY™	17
4.5.1 <i>EPO™</i>	17
4.5.2 <i>EASY™</i>	17
4.6 GNSS ANTENNA.....	18
4.6.1 <i>Internal Patch Antenna Specification</i>	18
4.6.2 <i>Application Notes</i>	19
4.6.3 <i>External Active Antenna</i>	20
4.7 ANTENNA STATUS INDICATOR	21
5. ELECTRICAL RELIABILITY AND RADIO CHARACTERISTICS	22
5.1 ABSOLUTE MAXIMUM RATINGS.....	22
5.2 RECOMMENDED OPERATING CONDITIONS.....	22
5.3 ELECTRO-STATIC DISCHARGE	23
6. MANUFACTURING	25
6.1 TOP AND BOTTOM VIEW OF N31B SERIES	25
6.2 PRODUCT LABELING.....	25
6.3 ASSEMBLY AND SOLDERING	26
6.4 MOISTURE SENSITIVITY.....	27
6.5 ESD HANDLING PRECAUTIONS	28

6.6 SHIPMENT.....	29
7. REFERENCE DESIGN.....	30
8. SAFETY INFORMATION.....	31
APPENDIX	31
A. RELATED DOCUMENTS.....	31
B. TERMS AND ABBREVIATIONS	31

LYNQ
CONFIDENTIAL

1. Introduction

This document describes the hardware interface of the MOBILETEK module N31B series which can be used as a stand-alone GNSS or A-GPS (Assisted Global Positioning System) receiver. As a wide range of applications can be integrated in N31B series, all functional components of N31B series are described in great detail.

2. N31B Series Overview

N31B series is GNSS module with built-in LNA and Patch Antenna(18.4*18.4*4.0mm), don't need an extra antenna and external LNA. N31B series can track as low as -165dBm signal level. The N31B series has excellent low power consumption characteristic. N31B series supports various location and navigation applications, including autonomous GPS/Galileo/Glonass/BD2/QZSS, EPO™, EASY™.

N31B series module not only supports automatic antenna switching function, which can achieve switching between external active antenna and internal patch antenna, but also supports external active antenna detection and short protection. The detection and notification of different external active antenna status will be shown in the NMEA message including external active antenna connection, open circuit for antenna and antenna short-circuited. So host can query the external active antenna status timely and conveniently.

N31B series has two detailed part numbers as below:

N31B: GPS+QZSS+BD2/GPS+QZSS+GLONASS;

N31B-H: GPS+QZSS+ GLONASS

Key Features

- GNSS receiver, supports QZSS, EPO™, EASY™
- 33 tracking/99 acquisition-channel, up to 210 PRN channels
- Small footprint: 16.0x 16.0 x 6.45mm, 12-pin LCC package
- Patch dimensions: 18.4x 18.4 x 4.0mm
- 12 multi-tone active interference cancellers and jamming elimination
- Indoor and outdoor multi-path detection and compensation
- Maximum NMEA update rate up to 10 Hz (w/o ading), 5 Hz (with ading)
- Advanced software features
 1. EASY™ self-generated orbit prediction
 2. EPO™ orbit prediction
 3. PPS sync NMEA
 4. supports logger function
 5. supports active interference cancellation (AIC)
- Pulse-per-second (PPS) GNSS time reference
 1. Adjustable duty cycle
 2. typical accuracy: $\pm 10\text{ns}$
- Interface
 - UART
- Operating temperature: $-40 \sim +85^{\circ}\text{C}$
- Accuracy 2.5m CEP@-130dBm
- RoHS compliant

The module provides complete signal processing from antenna input to host port in either NMEA messages. The module requires 3.3V~4.3V power supply. The host port is configurable to UART. Host data and I/O signal levels are 2.85V CMOS compatible.

2.1 N31B Series Functional Diagram

The following figure shows a functional diagram of the N31B series and illustrates the mainly

functional parts:

- The GNSS chip
- SAW filter
- LNA
- Patch Antenna interface
- The communication interface
- The control signals
- Automatic antenna switching function
- Support short circuit protection and antenna detection circuit for active antenna

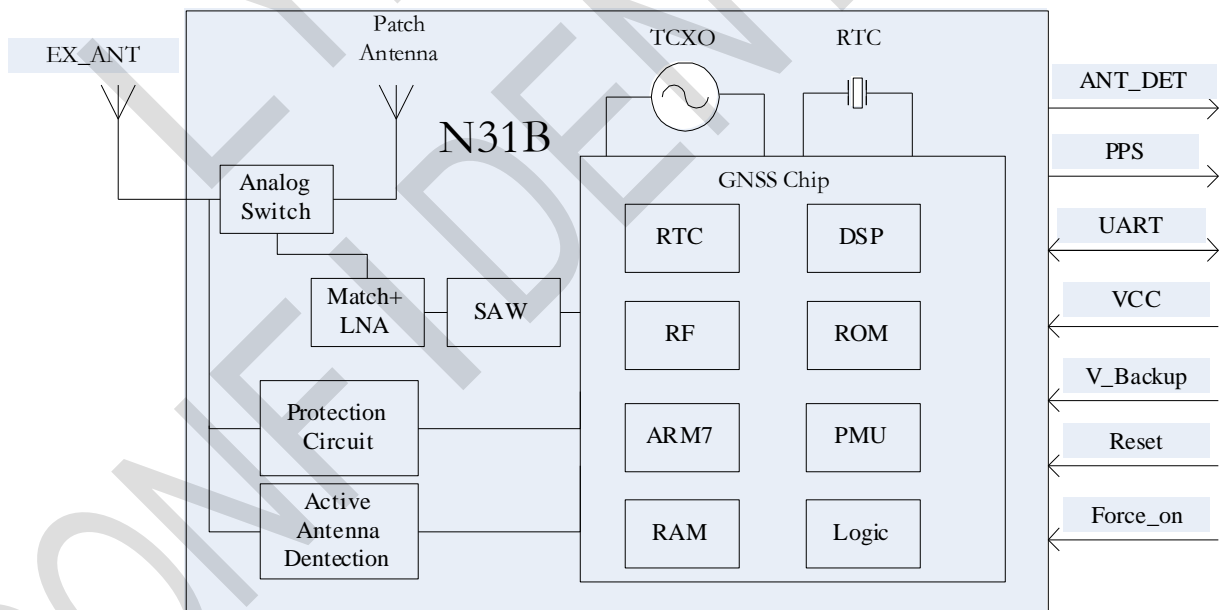

Figure 2-1 N31B series functional diagram

2.2 GNSS Performance

Table 2-1 GNSS performance

Parameter	Description	Performance			
		Min	Type	Max	Unit

N31B	Horizontal Position Accuracy ⁽¹⁾	Autonomous		<2.5		m	
	Velocity Accuracy ⁽²⁾	Without Aid		0.1		m/s	
	Acceleration Accuracy	Without Aid		0.1		m/s ²	
	Timing Accuracy			10		ns	
	Dynamic Performance	Maximum Altitude				18000	m
		Maximum Velocity				515	m/s
		Maximum Acceleration				4	G
	Time To First Fix ⁽³⁾ without EASY™	Hot start			<1		s
		Warm start			30		s
		Cold start			32		s
	TTFF with EASY™	Hot start			<1		s
		Warm start			5		s
		Cold start			15		s
	Sensitivity ⁽³⁾	Autonomous acquisition(cold start)			-148		dBm
		Re-acquisition			-160		dBm
		Tracking			-165		dBm
	Receiver	Channels		33 tracking/99 acquisition			
		Update rate			1	10	Hz
		Tracking L1, CA Code					
		Protocol support NMEA,PMTK					
	Power consumption ⁽⁴⁾	Acquisition			23.3		mA
		Continuous tracking			21.9		mA
		Standby current			600		uA
		Backup current			7		uA

N31B-H	Horizontal Position Accuracy ⁽¹⁾	Autonomous		<2.5		m	
	Velocity Accuracy ⁽²⁾	Without Aid		0.1		m/s	
	Acceleration Accuracy	Without Aid		0.1		m/s ²	
	Timing Accuracy			10		ns	
	Dynamic Performance	Maximum Altitude				18000	m
		Maximum Velocity				515	m/s
		Maximum Acceleration				4	G
	Time To First Fix ⁽³⁾ without EASY™	Hot start			<1		s
		Warm start			30		s
		Cold start			32		s
	TTFF with EASY™	Hot start			<1		s
		Warm start			5		s
		Cold start			15		s
	Sensitivity ⁽³⁾	Autonomous acquisition(cold start)			-148		dBm
		Re-acquisition			-160		dBm
		Tracking			-165		dBm
	Receiver	Channels		33 tracking/99 acquisition			
		Update rate			1	10	Hz
		Tracking L1, CA Code					
		Protocol support NMEA,PMTK					
Power consumption ⁽⁴⁾	Acquisition			23.62		mA	
	Continuous tracking			23.4		mA	
	Standby current			1.2		mA	
	Backup current			10		uA	

(1) 50% 24hr static, -130dBm

- (2) 50% at 30m/s
- (3) GNSS signal level: -130dBm
- (4) Single Power supply 3.3V@-130dBm

2.3 General features

Table 2-2 General features

Parameters	Value	
Supply voltage VCC	+3.3V~4.3V	
Supply voltage ripple VCC	54 mV(RMS) max @ f = 0~3MHz 15 mV(RMS) max @ f > 3 MHz	
Storage temperature	-45 ℃~+90 ℃	
Operating temperature	-40 ℃~+85 ℃ (note 1)	
I/O signal levels	V _{IL}	-0.3V~0.8V
	V _{IH}	2.0V~3.6V
	V _{OL}	-0.3V~0.4V
	V _{OH}	2.4V~3.1V
I/O output sink/source capability	+/- 3mA max	
I/O input leakage	+/- 10uA max	
Host port	UART	
Serial port protocol (UART)	NMEA:8 bits, no parity, 1 stop bit, 115200 bps	
TIMEMARK output (1PPS)	1 pulse per second, synchronized at rising edge, pulse length100ms	

Notes: Operation in the temperature range -40℃~ -30℃ is allowed but Time-to-First-Fix performance and tracking sensitivity may be degraded.

3. Package Information

3.1 Pin out Diagram

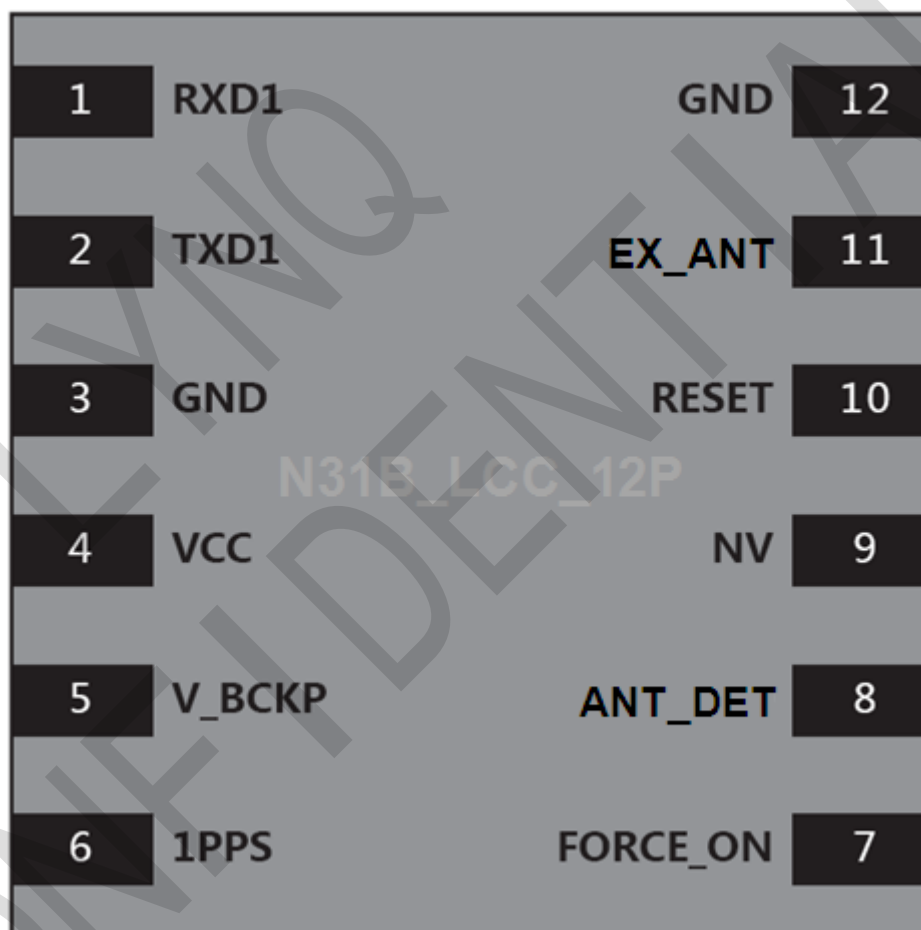

Figure 3-1 N31B series pin out diagram (Top view)

3.2 Pin Description

Table 3-1 Pin description

Pin name	Pin NO.	I/O	Description	Comment
Power supply				
VCC	4	I	Main power input, Typical: 3.3V. Recommend LDO as VCC, ripple	Add a 4.7uF capacitor to this pin for

			rejection: >60dB@1kHz	decoupling
V_BCKP	5	I	The backup battery input power supply for RTC 2.0V~4.3V, Typical 3.0V	If unused, keep open
GND	3 12		Ground	
Host port interface				
TXD1	2	O	Serial data output of NMEA	
RXD1	1	I	Serial data input for firmware update	
GPIOs				
1PPS	6	O	1PPS Time Mark Output 2.85V CMOS Level ,timing pulse related to receiver time	If unused, keep open
FORCE_ON	7	I	Logic high will Force module to be waked up from backup mode	Keep this pin open or pulled low before Entering into backup mode. If unused, keep open
RESET	10	I	Reset input, active low. default pull-up	If unused, keep open
RF interface				
EX_ANT	11	I	External active antenna RF input	If unused, keep this pin open.
Other interface				
ANT_DET	8	O	Active antenna detection $V_{OH}=3.0V\sim 4.0V$ $V_{OL}=0V\sim 0.7V$	If unused, keep this pin open. Refer to chapter 4.7.
NV	9		Not Connected	

3.3 Package Dimensions

Following figure shows the Mechanical dimensions of N31B series (top view, side view and bottom view).

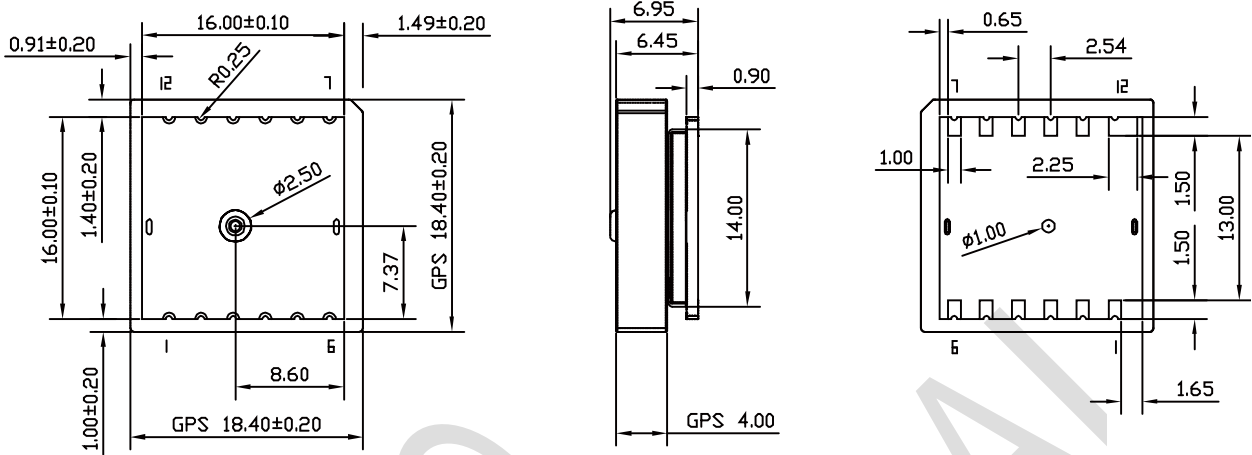

Figure 3-2 N31B Series mechanical dimensions (Unit: mm)

3.4 N31B Series Recommended PCB Decal

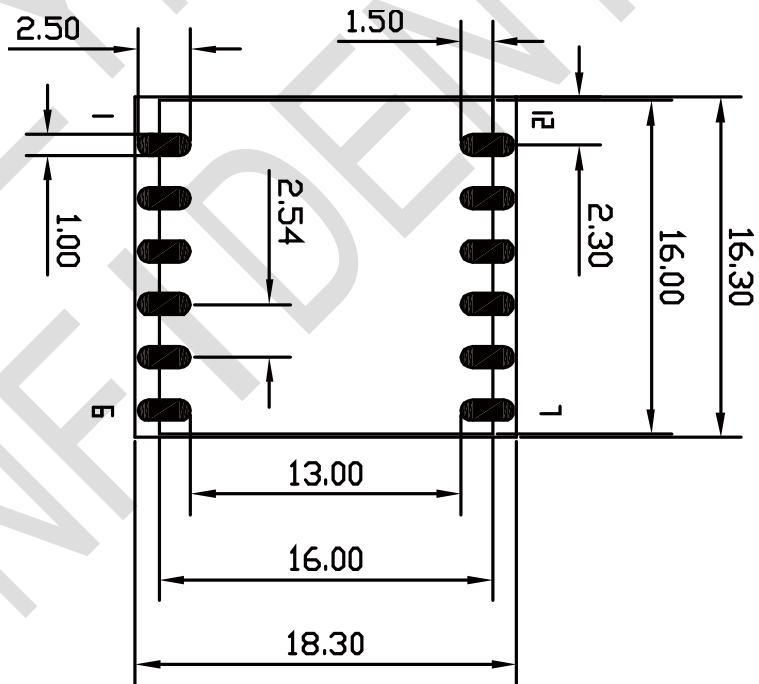

Figure 3-3 Recommended PCB decal (top view) (Unit: mm)

4 . Application Interface

4.1 Power Management

4.1.1 Power Input

The power supply range of N31B series is from 3.3V to 4.3V. The power supply should be able to provide sufficient current up to 100mA. The power supply range of V_BCKP is from 2V to 4.3V, typical 3.0V. Suggest customer keep the V_BCKP supply active all the time, the module will perform a quick start every time it is power-on.

4.1.2 Starting N31B Series

When power is first applied, N31B series goes into operation mode.

4.1.3 Verification of N31B Series Start

System activity indication depends upon the chosen serial interface. When it is activated, N31B series will output messages at the selected UART speed and message types.

4.1.4 Power Saving Modes

N31B series supports operating modes for reduced average power consumption like standby mode, backup mode, periodic mode.

- Standby mode: In this mode the receiver stays at full on power state. When this mode that can be wake up by the host sends the command through the communication interface.
- Backup mode: In this mode the N31B series must be supplied by the V_BCKP pin and the VCC power should be cut off. The module could not achieve this mode through PMTK commands.

N31B series provides very low leakage battery back up memory, which contains all the necessary GNSS information for quick start up and a small amount of user configuration variables. It needs a 3V power supply for V_BCKP pin.

- periodic mode: In this mode the N31B series enters tracking and standby or Backup mode according to the interval configured.

4.1.5 Operating Mode

Table 4-1 Power supply and clock state according to operation mode

Mode	VCC	V_BCKP	Internal LDO	Main Clock	RTC Clock
Full on	on	on	on	on	on
Standby	on	on	off	off	on
Backup	off	on	off	off	on

Full on Mode

The module will enter full on mode after first power up with factory configuration settings. Power consumption will vary depending on the amount of satellite acquisitions and number of satellites in track.

Standby Mode

Standby mode means a low quiescent power state, non-volatile RTC, and backup RAM block is powered on. Other internal blocks like digital baseband and RF are internally powered off. The power supply input VCC shall be kept active all the time, even during standby mode.

Entering into standby mode is sent PMTK command “\$PMTK161,0*28” through the communication interface by host side. Waking up from standby mode is sent any byte through the communication interface by host side.

Backup Mode

Power source (such as battery or cap) connected to V_BCKP pin will help the chipset in keeping its internal RTC running when the VCC power source is turned off. The voltage should be kept between 2.0~4.3V, Typical 3.0V.

The V_BCKP power should be kept active all the time, the module will perform a quick start every time it is power-on.

Entering into standby mode is sent PMTK command “\$PMTK225,4*2F” and keep FORCE_ON low. The only way to wake up the module is pulling the FORCE_ON high.

Periodic Mode

In this mode the N31B series enters tracking and standby or Backup mode according to the interval configured.

Table 4-2 PMTK225 Command Format

Format: \$PMTK225,<Type>,<Run_time>,<Sleep_time>,<2nd_run_time>,<2nd_sleep_time>*<checksum><CR><LF>		
Parameter	Format	Description
Type	Decimal	0:full on mode 1:Periodic Backup Mode 2:Periodic standby Mode 4: Backup Mode
Run_time	Decimal	Full on mode period
Sleep_time	Decimal	Standby/Backup mode period
2nd_run_time	Decimal	Full on mode period for 2nd acquisition when module acquisition fails during the Run_time
2nd_sleep_time	Decimal	Standby/Backup mode period for 2nd sleep when module acquisition fails during the Run_time
Checksum	Hexadecimal	Hexadecimal checksum

The average current value can be calculated by the following formula:

$$I_{\text{periodic}} = (I_{\text{tracking}} * T_{\text{run_time}} + I_{\text{sleep/backup}} * T_{\text{sleep_time}}) / (T_{\text{run_time}} + T_{\text{sleep_time}})$$

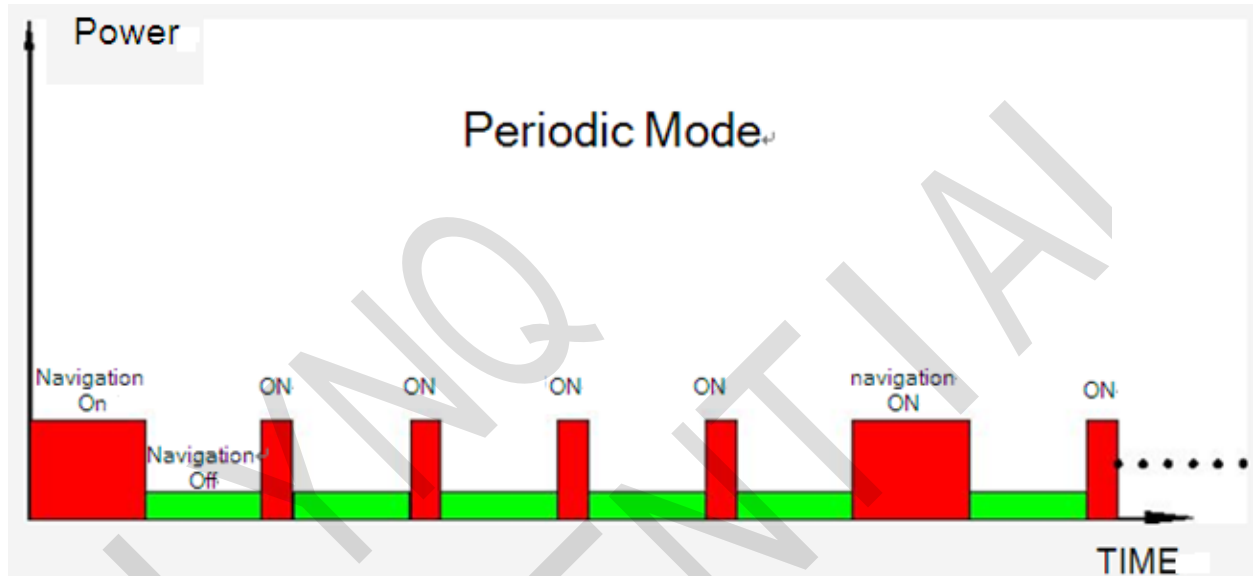

Figure 4-1 Periodic Mode

4.2 UART Interface

The interface for serial communication of N31B series is UART. The UART is as NMEA output and PMTK command input. The receiver (RX) and transmitter (TX) side of every port contains a 16-byte FIFO. UART can provide the developers signal or message outputs. The default baud rate is 115200 bps.

4.3 RESET Input

The RESET pin (active low) is used to reset the system, normally external control of RESET is not necessary. The signal can be left floating, if not used.

When RESET signal is used, it will force volatile RAM data loss. Note that Non-Volatile backup RAM content is not cleared and thus fast TTF is possible. The input has internal pull up.

4.4 1PPS Output

The 1PPS pin outputs one pulse-per-second (1PPS) pulse signal for precise timing purposes. The 1PPS signal can be provided through designated output pin for many external applications. This pulse is not only limited to be active every second but also allowed to set the required duration frequency, and active high/low by programming user-defined settings.

4.5 A-GPS and EASY™

A-GPS is the meaning of Assisted GPS, which is a system that can improve the startup performance, and time-to-first-fix (TTFF) of a GNSS satellite-based positioning under certain conditions. N31B series module supports EPO™ file, EASY™.

4.5.1 EPO™

The N31B series supports the EPO (Extended Prediction Orbit) data service. The EPO data service is supporting 6 hours orbit predictions to customers. It needs occasional download from EPO server. Supply of aiding information like ephemeris, almanac, rough last position and time and satellite status and an optional time synchronization signal will reduce time to first fix significantly and improve the acquisition sensitivity.

The user should update the EPO files from the EPO server daily through the internet. Then the EPO data should send to the N31B series by the HOST side. N31B series has the short cold TTFF and warm TTFF, when the EPO is used.

Note: For more information about EPO, please contact Mobiletek sales.

4.5.2 EASY™

N31B series supports EASY™ (Embedded Assisted System) is Self-Generated Orbit Prediction feature. By comparison EPO/Hot Still/AGPS, it provides up to 3 days GNSS orbit prediction ability without any host CPU portioning or internet connection requirement.

V_BCKP must be supply always on power for keeping EASY™ Self-Generated Orbit Prediction feature.

4.6 GNSS Antenna

N31B series has integrated a internal GNSS antenna,which is a passive patch antenna.Patch antenna size is 18.4*18.4*4mm. In addition,N31B series module can also support external active antenna, and the RF signal is obtained from the EX_ANT pin. Both internal patch signal and external active antenna signal are intelligently switched through Analog switch.

4.6.1 Internal Patch Antenna Specification

The specifications of the integrated GNSS antenna are presented as following table:

Table 4-3 Antenna Specifications

Parameter	Specification	
Passive Antenna Recommendations	Frequency range	GPS:1575 ±1.023MHz BD2 :1561.098 ±2.046 MHz
	Band Width	10MHz
	Frequency Temperature Coefficient	0 ±20ppm/°C
	Polarization	RHCP
	Gain at Zenith	3dBic
	VSWR	<1.5dB
	Impedance	50Ω

The test result of the antenna is shown as the following figure. The GNSS antenna provides good radiation efficiency,right hand circular polarization and optimized radiation pattern.

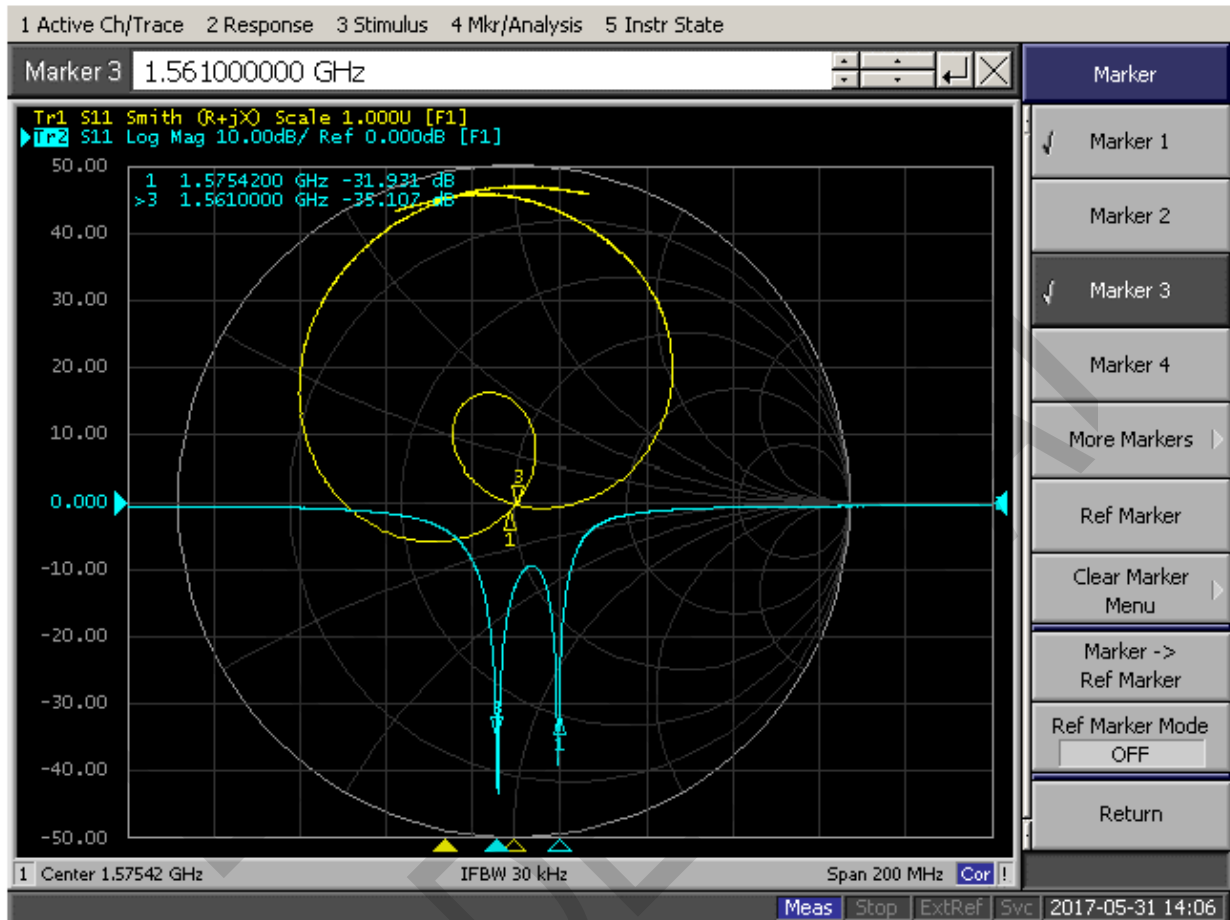

Figure 4-3 Patch Antenna Test Result with Ground Plane 35.0mm*55.0mm

4.6.2 Application Notes

The GNSS Patch antenna consists of a radiating patch on one side of a dielectric material substrate backed by a ground plane on the other side.

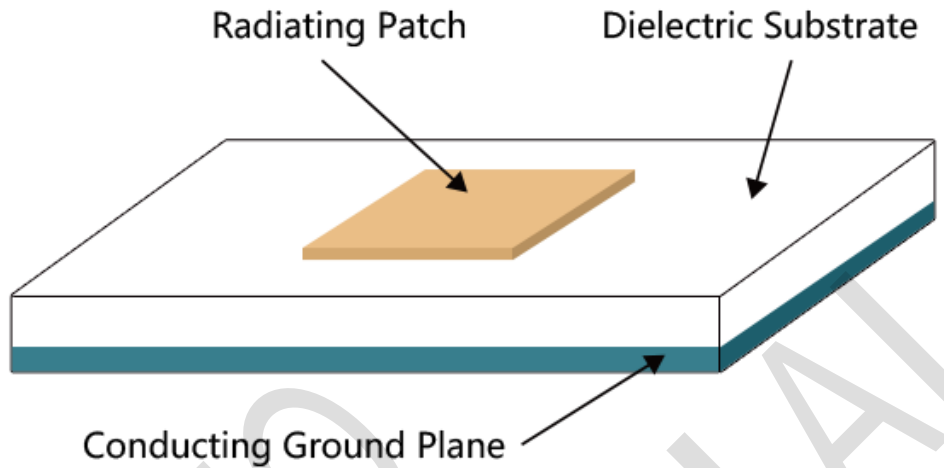

Figure 4-4 GNSS Patch antenna on the Main Board

Customer can refer to the following rules, when the N31B series is integrated into the main Board:

1. The most important rule is to ensure the antenna towards the sky.
2. The antenna should not be covered by any metalized enclosure or metal device.
3. The antenna must be placed far away from memory, camera, LCM, TP, DCDC etc high power high heat area.
4. The height of device around the module, should not exceed the antenna. The components which height is more than 6.4mm, must be kept more than 10mm distance away from module.

4.6.3 External Active Antenna

The following figure is a typical reference design with active antenna. In this mode, DC on the EX_ANT pin is powered by VCC and supplies power to the external active antenna.

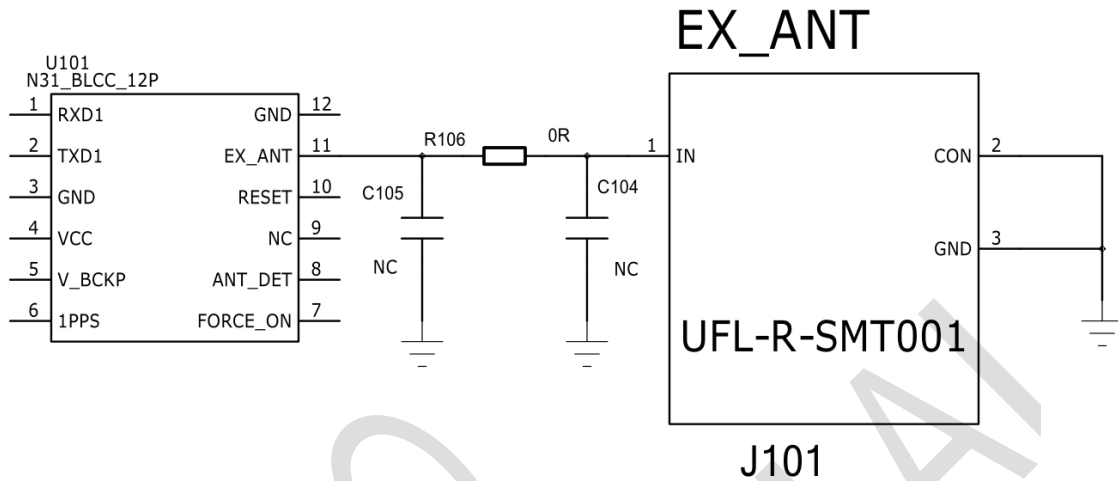

Figure 4-5 Reference Design for Active Antenna

C104,R106,C105 are reserved matching circuit for antenna impedance modification.By default,C104 and C105 are not mounted;R106 is 0 ohm. In this mode,R106 must not be capacitance, as current will stream through R106 to the active antenna.C105 and C104 must not be inductance or resistance to avoid short circuit.

The impedance of RF trace line in main PCB should be controlled as 50 Ohm, and the trace length should be kept as short as possible.

4.7 Antenna Status Indicator

N31B series module supports automatic antenna switching function. The GPTXT sentence can be used to identify the status of external active antenna.

If ANTSTATUS=OPEN, it means external active antenna is not connected or has poor contact with antenna feeding point and the internal antenna is used.

If ANTSTATUS=OK, it means external active antenna is connected and the module will use external active antenna.

If ANTSTATUS=SHORT, it means active antenna is short circuited and the internal patch antenna will be used automatically.

Notes: Because antenna short protection is enabled by default, N31B series module will switch to embedded patch antenna automatically in case that external active antenna is short-circuited, which will avoid N31B series module from damage. Meanwhile, you need to check the external active

Table 4-4 GPTXT - Status of Antenna

GPTXT Display	Ext Active Antenna Status	Inner Patch Antenna Status	Attention
OPEN	Unused	Working	You need to check the external active antenna status if the active antenna is used.
OK	Working	Unused	
SHORT	Short	Working	Please check the external active antenna.

The pin “ANT_DET” also can be used to indicate the status of active antenna. When active antenna is not connected to EX_ANT or has poor contact with antenna feeding point, “ANT_DET” will keep a high level to indicate the absence of the active antenna. “ANT_DET” will change to a low level when active antenna is connected well.

**Notes: Active antenna is only available when the voltage of ANT_DET \leq 0.7 V.
The ANT_DET high level voltage range is 3.0V~4.0V.**

5. Electrical Reliability and Radio Characteristics

5.1 Absolute Maximum Ratings

The absolute maximum ratings stated in Table 5-1 are stress ratings under non-operating conditions. Stresses beyond any of these limits will cause permanent damage to N31B series.

Table 5-1 Absolute maximum ratings

Parameter	Min	Max	Unit
VCC		4.3	V
Input Power at GNSS_ANT		-12	dBm
V_BCKP		4.3	V
I/O pin voltage		3.6	V
Storage temperature	-40	+85	°C
Operating Temperature	-40	+85	°C

5.2 Recommended Operating Conditions

Table 5-2 N31B Series operating conditions

Parameter	Symbol	Min	Type	Max	Unit
Operating temperature range		-40	+25	+85	°C
Main supply voltage	VCC	3.3	3.8	4.3	V
Backup battery voltage	V_BCKP	2.0	3	4.3	V

Table 5-3 N31B Series standard IO features

Parameter	Symbol	Min	Type	Max	Unit
Low level output voltage Test conditions $I_{OL} = 2\text{mA}$ and 4.0mA	V_{OL}	-0.3		0.40	V
High level output voltage Test conditions $I_{OL} = 2\text{mA}$ and 4.0mA	V_{OH}	2.4	2.8	3.1	V
Low level input voltage	V_{IL}	-0.3		0.8	V
High level input voltage	V_{IH}	2.0		3.6	V
Input Pull-up resistance	R_{PU}	40		190	K Ω
Input Pull-down resistance	R_{PD}	40		190	K Ω
Input capacitance	C_{IN}		5		pF
Load capacitance	C_{load}			8	pF
Tri-state leakage current	I_{OZ}	-10		10	μA

5.3 Electro-Static Discharge

The GNSS engine is not protected against Electrostatic Discharge (ESD) in general. Therefore, it is subject to ESD handling precautions that typically apply to ESD sensitive components. Proper ESD handling and packaging procedures must be applied throughout the processing, handling and operation of any application using a N31B series module. The ESD test results are shown in the following table.

Table 5-4 The ESD characteristics (Temperature: 25°C, Humidity: 45 %)

Pin	Contact discharge	Air discharge
VCC	$\pm 5\text{KV}$	$\pm 10\text{KV}$
EX_ANT	$\pm 5\text{KV}$	$\pm 10\text{KV}$
V_BCKP	$\pm 5\text{KV}$	$\pm 10\text{KV}$
GND	$\pm 5\text{KV}$	$\pm 10\text{KV}$

RXD, TXD	$\pm 4\text{KV}$	$\pm 8\text{KV}$
RESET	$\pm 4\text{KV}$	$\pm 8\text{KV}$

LYNQ
CONFIDENTIAL

6. Manufacturing

6.1 Top and Bottom View of N31B Series

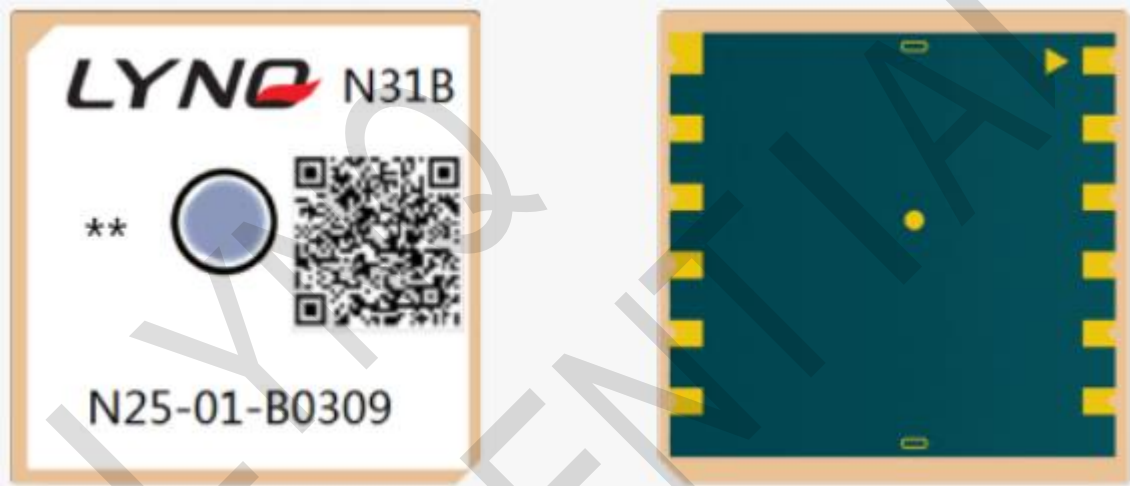

Figure 6-1 Top and bottom view of N31B series

6.2 Product labeling



Figure 6-2 Label of N31B series

Table 6-1 Description of module label

Item	Description
A	Pin1 mark
B	Logo of company
C	Satellite system and baud rate; Example B:GPS+BD2 G:GPS+Glonass;9:9600 ,1:115200 ;
D	Module name
E	QR code --- include hardware and software edition, date of manufacture, and baud rate, etc.
F	PID number

6.3 Assembly and Soldering

The N31B series module is intended for SMT assembly and soldering in a Pb-free reflow process on the top side of the PCB. Suggested solder paste stencil height is 150um minimum to ensure sufficient solder volume. If required paste mask pad openings can be increased to ensure proper soldering and solder wetting over pads.

The following figure is the Ramp-Soak-Spike Reflow Profile of N31B series:

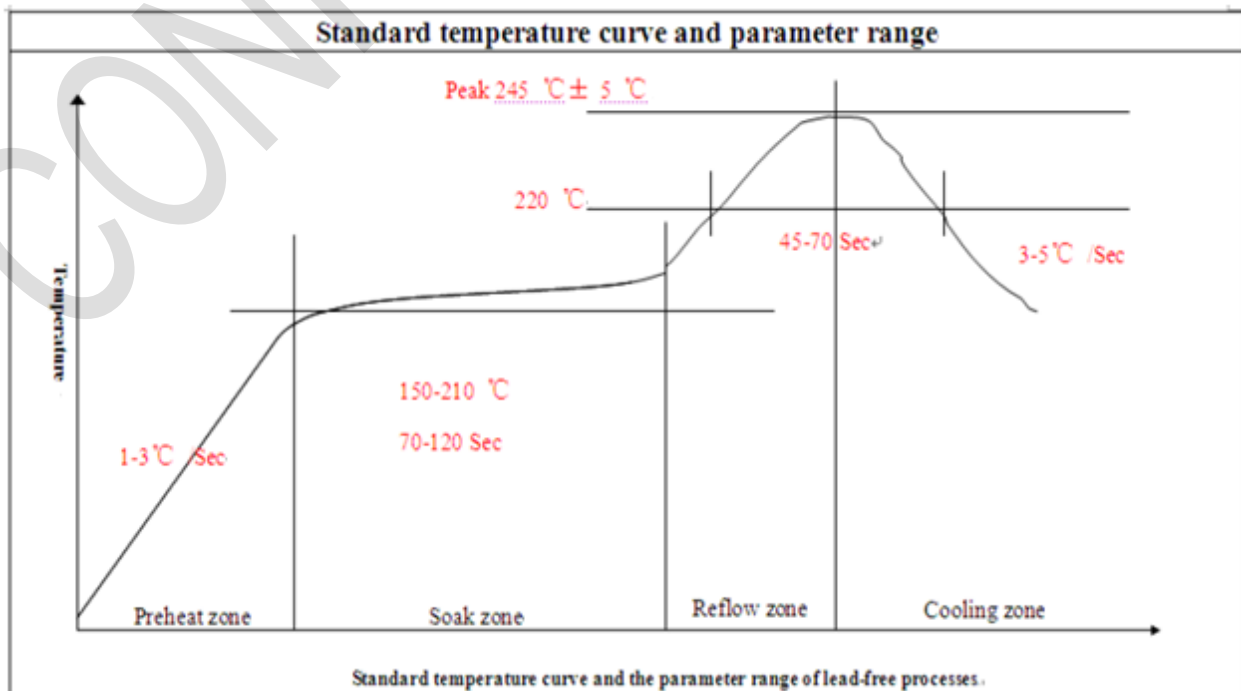

Figure 6-3 The Ramp-Soak-Spike reflow profile of N31B series

N31B series is Moisture Sensitive Devices (MSD), appropriate MSD handling instruction and precautions are summarized in Chapter 6.3.

N31B series modules are also Electrostatic Sensitive Devices (ESD), handling N31B series modules without proper ESD protection may destroy or damage them permanently. Avoid ultrasonic exposure due to internal crystal and SAW components.

6.4 Moisture sensitivity

N31B series module is moisture sensitive at MSL level 3, dry packed according to IPC/JEDEC specification J-STD-020C. The calculated shelf life for dry packed SMD packages is a minimum of 6 months from the bag seal date, when stored in a non condensing atmospheric environment of <math><40^{\circ}\text{C}/90\% \text{RH}</math>.

Table 6-2 lists floor life for different MSL levels in the IPC/JDEC specification:

Table 6-2 Moisture Classification Level and Floor Life

Level	Floor Life(out of bag)at factory ambient $\leq +30^{\circ}\text{C}/60\% \text{RH}$ or as stated
1	Unlimited at $\leq +30^{\circ}\text{C}/85\% \text{RH}$
2	1 year
2a	4 weeks
3	168 hours
4	72 hours
5	48 hours
5a	24 hours
6	Mandatory bake before use. After bake, module must be reflowed within the time limit specified on the label.

Factory floor life is 1 week for MSL 3, N31B series must be processed and soldered within the time. If

this time is exceeded, the devices need to be pre-baked before the reflow solder process.

Both encapsulate and substrate materials absorb moisture. IPC/JEDEC specification J-STD-020 must be observed to prevent cracking and delamination associated with the "popcorn" effect during reflow soldering. The popcorn effect can be described as miniature explosions of evaporating moisture. Baking before processing is required in the following case:

Floor life or environmental requirements after opening the seal have been exceeded, e.g. exposure to excessive seasonal humidity.

Refer to Section 4 of IPC/JEDEC J-STD-033 for recommended baking procedures.

6.5 ESD handling precautions

N31B series modules are Electrostatic Sensitive Devices (ESD). Observe precautions for handling! Failure to observe these precautions can result in severe damage to the GNSS receiver!



GNSS receivers are Electrostatic Sensitive Devices (ESD) and require special precautions when handling. Particular care must be exercised when handling patch antennas, due to the risk of electrostatic charges. In addition to standard ESD safety practices, the following measures should be taken into account whenever handling the receiver.

Unless there is a galvanic coupling between the local GND (i.e. the work Table) and the PCB GND, then the first point of contact when handling the PCB shall always be between the local GND and PCB GND. Before mounting an antenna patch, connect ground of the device

When handling the RF pin, do not come into contact with any charged capacitors and be careful when contacting materials that can develop charges (e.g. patch antenna ~10pF, coax cable ~50-80pF/m, soldering iron, ...) To prevent electrostatic discharge through the RF input, do not touch the mounted patch antenna.

When soldering RF connectors and patch antennas to the receiver's RF pin, the user must make sure to use an ESD safe soldering iron (tip).

6.6 Shipment

N31B series is designed and packaged to be processed in an automatic assembly line, and it is now packaged tray and reel.

LYNQ
CONFIDENTIAL

7. Reference Design

Refer to the “N31B Series_REF_SCH_V1_181128” document for details of the reference design.

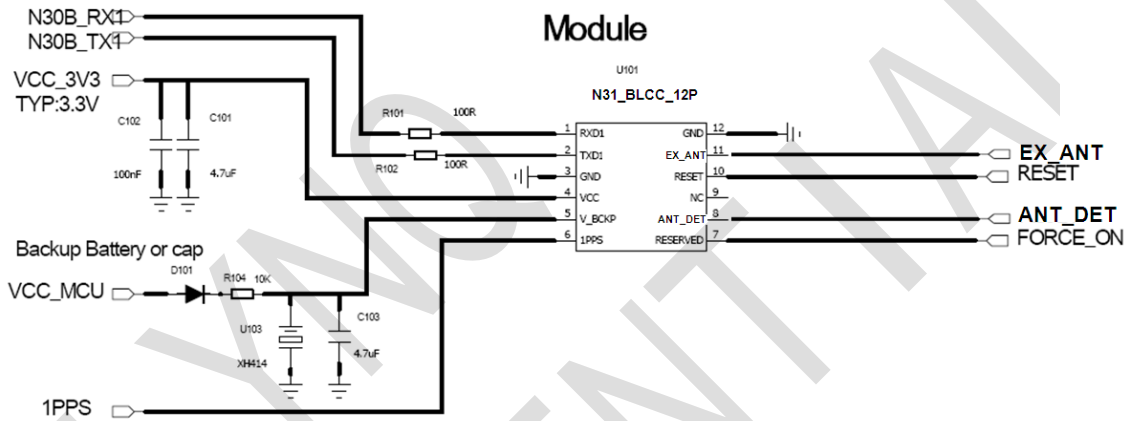

Figure 7-1 Application schematics

8. Safety Information

For the reasonable usage of the module, please comply with all these safety notices of this page. The product manufacturers should send followed safety information to user, operator or product's spec.



The devices using the module may disturb some electronic equipment. Put the module away from the phone, TV, radio and automation equipment to avoid the module and the equipment to interfere with each other.



Shut down the mobile device or change to flying mode before boarding. The Using of wireless appliances in an aircraft is forbidden to avoid the interference, or else cause to unsafe flying, even violate the law.



In hospital or health care center, switch off the mobile devices. RF interference may damage the medical devices, like hearing-aid, cochlear implant and heart pacemaker etc.



Mobile devices can't guarantee to connect in all conditions, like no fee or with an invalid SIM card. When you need emergent help, please remember using emergency calls and make sure your device power on in an area with well signal



Put the module away from inflammable gases. Switch off the mobile device when close to gas station, oil depot, chemical plant etc.



The module is not water proof. Please don't use the module in the area with high humidity like bathroom, which will decelerate the physical performance, insulation resistance and mechanical strength.



Non-professionals can't teardown the module which will damage it. Refer to the specification or communicate the related staffs to repair and maintain it.



Please switch on the module before cleaning. The staffs should be equipped with anti-ESD clothing and gloves.

The users and product manufacturers should abide by the national law of wireless modules and devices. If not, Mobiletek will not respond the related damages.

Appendix

A. Related Documents

Table 13 Related documents

SN	Document name	Remark
[1]	LYNQ_GNSS_SDK_Commands_Manual	
[2]	EPO-II Format Protocol Customer	

B. Terms and Abbreviations

Abbreviation	Description
A-GPS	Assisted Global Positioning System
CMOS	Complementary Metal Oxide Semiconductor
CEP	Circular Error Probable
EEPROM	Electrically Erasable Programmable Read Only Memory
EPO	Extended Prediction Orbit
ESD	Electrostatic Sensitive Devices
EASY	Embedded Assist System
GPS	Global Positioning System
GNSS	Global Navigation Satellite System
I/O	Input / Output
IC	Integrated Circuit
Inorm	Normal Current
Imax	Maximum Load Current
kbps	Kilo bits per second

MSL	moisture sensitive level
MSAS	Multi-Functional Satellite Augmentation System
NMEA	National Marine Electronics Association
PRN	Pseudo Random Noise Code
QZSS	Quasi-Zenith Satellites System
SBAS	Satellite Based Augmentation Systems
WAAS	Wide Area Augmentation System