

250W isolated DC-DC converter  
Ultra-wide input and regulated single output



FEATURES

- Ultra-wide input voltage range: 40 -160VDC
- High efficiency up to 90%
- Reinforced insulation, I/O isolation test voltage 3k VAC
- Operating ambient temperature range -40°C to +105°C
- Input under-voltage protection, output over-voltage, over-current, short-circuit protection, over-temperature protection
- Industry standard 1/2-Brick package and pin-out
- EN50155 approved

URF1DxxHB-250(H)WR3(A5) series is a high-performance product specifically designed for a variety of railway applications. The DC-DC converters feature 250W output power with no requirement for minimum load, wide input voltage from 40-160VDC, and allowing operating temperature as high as 105°C. Additional product features include input under-voltage protection, output over-voltage, short-circuit, over-current and over-temperature protection, remote On/Off control, remote sense compensation, output voltage trim adjustment. EN50155 approved and they are widely used in the centralized lighting, air conditioning and related in on-board equipment.

Selection Guide

Certification	Part No. ①	Ctrl Logic ②	Input Voltage (VDC)			Output		Full Load Efficiency(%) Min./Typ.	Max. Capacitive Load(μF)
			Nominal	Range	Max. ③	Voltage (VDC)	Current (mA) Max./Min.		
CE	URF1D05HB-250W(H)R3	P	110	40-66	170	5	40000/0	87/88	22000
	URF1D12HB-250W(H)R3	P		66-160			16670/0		
	URF1D15HB-250W(H)R3	P		40-66		12	20840/0	88/90	6800
				66-160			13330/0		
URF1D24HB-250W(H)R3	P	40-66		15		16670/0	88/90	4000	
		66-160				8330/0			
-	URF1D40HB-250W(H)R3	P		40-66		40	5000/0	87/89	680
				66-160			6250/0		
CE	URF1D48HB-250W(H)R3	P		40-66		48	4160/0	88/90	680
				66-160			5200/0		
	URF1D54HB-250W(H)R3	P		40-66		54	3700/0	88/90	680
				66-160			4630/0		
	URF1D05HB-250WR3A5	P	40-66	5	40000/0	87/88	22000		
			66-160		16670/0				
	URF1D12HB-250WR3A5	P	40-66	12	20840/0	88/90	10000		
			66-160		13330/0				
	URF1D15HB-250WR3A5	P	40-66	15	16670/0	88/90	6800		
			66-160		8330/0				
URF1D24HB-250WR3A5	P	40-66	24	10420/0	88/90	4000			
		66-160		10420/0					

CE	URF1D48HB-250WR3A5	P	110	40-66	170	48	4160/0	88/90	680
				66-160			5200/0		
	URF1D54HB-250WR3A5	P		40-66		54	3700/0	88/90	680
				66-160			4630/0		

Note:  
 ①Use "H" suffix for heat sink mounting. "A5" suffix for chassis mounting. We recommend to choose modules with a heat sink for enhanced heat dissipation and applications with extreme temperature requirements;  
 ②"P" means positive logic, "N" means negative logic;  
 ③Exceeding the maximum input voltage may cause permanent damage.

### Input Specifications

Item	Operating Conditions	Min.	Typ.	Max.	Unit	
Input Current (full load/no-load)	Nominal input voltage	5V output	--	2582/50	2612/70	mA
		Others	--	2526/50	2582/70	
Reflected Ripple Current	Nominal input voltage	--	100	--		
Surge Voltage (1sec. max.)		-0.7	--	185	VDC	
Start-up Voltage		--	--	40		
Input Under-voltage Protection		32	36	--		
Start-up Time	Nominal input voltage, constant resistance load	--	40	100	ms	
Input Filter		Pi filter				
Hot Plug		Unavailable				
Ctrl <sup>①</sup>	Module on	Ctrl open circuit or connected to TTL high level (3.5-12VDC)				
	Module off	Ctrl pin connected to -Vin or low level (0-1.2VDC)				
	Input current when off	--	5	10	mA	

Note: ①The Ctrl pin voltage is referenced to input -Vin.

### Output Specifications

Item	Operating Conditions	Min.	Typ.	Max.	Unit
Voltage Accuracy		--	±1	±3	%
Linear Regulation	Input voltage variation from low to high at full load	--	±0.2	±0.5	
Load Regulation	Nominal input voltage, 0%-100% load	5V output	--	±0.8	
		Others	--	±0.4	±0.5
Transient Recovery Time	25% load step change @25°C	--	200	500	µs
Transient Response Deviation		--	±3	±5	%
Temperature Coefficient	Full load	--	--	±0.03	%/°C
Ripple & Noise <sup>①</sup>	20MHz bandwidth, 0%-100%load	--	120	200	mVp-p
Trim		90	--	110	%Vo
Sense		--	--	105	
Over-temperature Protection	Max. Case Temperature	--	105	115	°C
Over-voltage Protection	Input voltage range	110	130	160	%Vo
Over-current Protection		110	140	150	%Io
Short-circuit Protection		Continuous, self-recovery			

Note: ①For ripple and noise measuring method, please refer to Fig.1

### General Specifications

Item	Operating Conditions	Min.	Typ.	Max.	Unit	
Isolation	Electric Strength Test for 1 minute with a leakage current of 5mA max	Input-output	3000	--	--	VAC
		Input-case	1500	--	--	
		Output-case	1500	--	--	

Insulation Resistance	Input-output resistance at 500VDC	100	--	--	MΩ
Isolation Capacitance	Input-output capacitance at 100KHz/0.1V	--	1000	--	pF
Operating Temperature	See temperature derating curves	-40	--	+105	℃
Storage Temperature		-55	--	+125	
Storage Humidity	Non-condensing	5	--	95	%RH
Pin Soldering Resistance Temperature	Wave-soldering, 10 seconds	--	--	260	℃
	Soldering spot is 1.5mm away from case for 10 seconds	--	--	300	
Cooling Requirement		EN60068-2-1			
Dry-heat Requirement		EN60068-2-2			
Damp-heat Requirement		EN60068-2-30			
Shock And Vibration		IEC/EN61373 - Category 1, Grade B			
Switching Frequency	PFM mode	--	260	--	KHz
MTBF	MIL-HDBK-217F@25℃	1000	--	--	K hours

### Mechanical Specifications

Case Material	Aluminum alloy case; Black plastic bottom, flame-retardant and heat-resistant (UL94 V-0)				
Dimension	URF1D_HB-250WR3	61.00 x 57.90 x 13.80mm			
	URF1D_HB-250WHR3	62.00 x 58.00 x 31.80mm			
	URF1D_HB-250WR3A5	135.00 x 70.00 x 22.40mm			
Weight	URF1D_HB-250WR3	135g (Typ.)			
	URF1D_HB-250WHR3	185g (Typ.)			
	URF1D_HB-250WR3A5	214g (Typ.)			
Cooling Method	Free air convection (20LFM) or forced air convection				

### Electromagnetic Compatibility (EMC)

Emissions	CE	CISPR32/EN55032	CLASS A (see Fig.3 for recommended circuit)		
	RE	CISPR32/EN55032	CLASS A (see Fig.3 for recommended circuit)		
Immunity	ESD	IEC/EN61000-4-2	Contact ±6KV Air ±8KV		perf.Criteria A
	RS	IEC/EN61000-4-3	20V/m		perf.Criteria A
	EFT	IEC/EN61000-4-4	±2KV(see Fig.3 for recommended circuit)		perf.Criteria A
	Surge	IEC/EN61000-4-5	differential mode ±1KV, 1.2/50us, source impedance 2Ω (see Fig.3 for recommended circuit)		perf.Criteria A
	CS	IEC/EN61000-4-6	10 Vr.m.s		perf.Criteria A

### Electromagnetic Compatibility (EMC) (EN50155)

Emissions	CE	EN50121-3-2	150kHz-500kHz 99dBuV (see Fig.3 for recommended circuit)		
		EN55016-2-1	500kHz-30MHz 93dBuV		
Immunity	RE	EN50121-3-2	30MHz-230MHz 40dBuV/m at 10m (see Fig.3 for recommended circuit)		
		EN55016-2-1	230MHz-1GHz 47dBuV/m at 10m		
	ESD	EN50121-3-2	Contact ±6KV/Air ±8KV		perf. Criteria A
	RS	EN50121-3-2	20V/m		perf. Criteria A
	EFT	EN50121-3-2	±2kV 5/50ns 5kHz (see Fig.3 for recommended circuit)		perf. Criteria A
Surge	EN50121-3-2	line to line ±1KV (42Ω, 0.5μF) (see Fig.3 for recommended circuit)		perf. Criteria A	
CS	EN50121-3-2	0.15MHz-80MHz 10 Vr.m.s		perf. Criteria A	

Typical Performance Curves

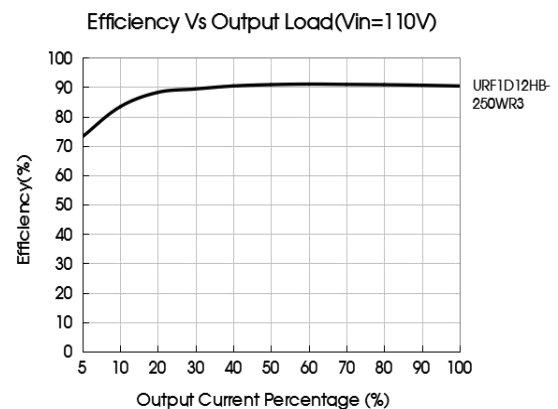
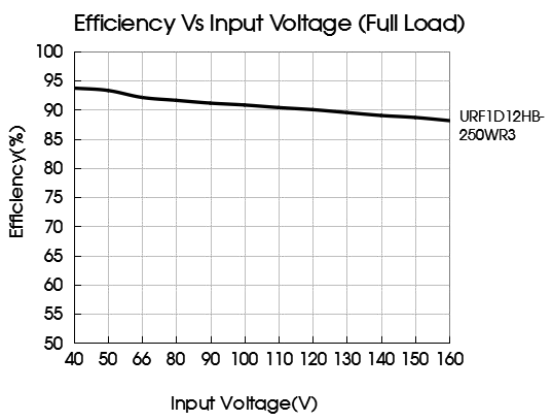
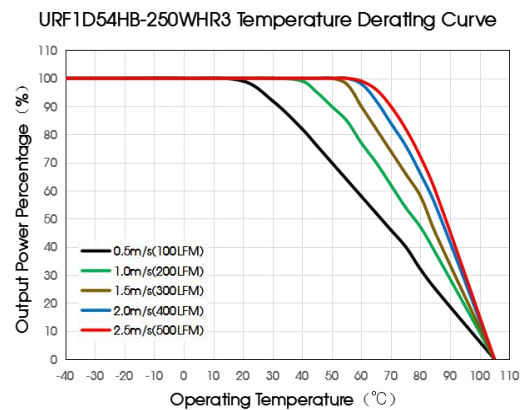
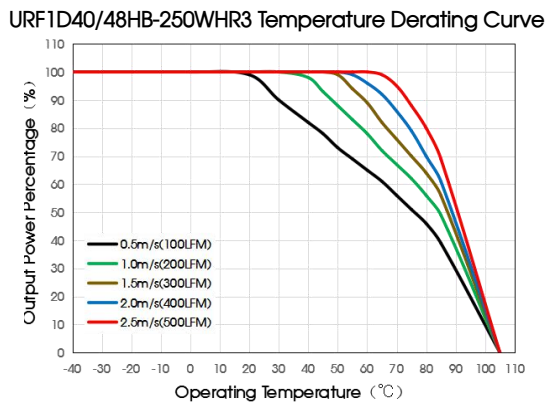
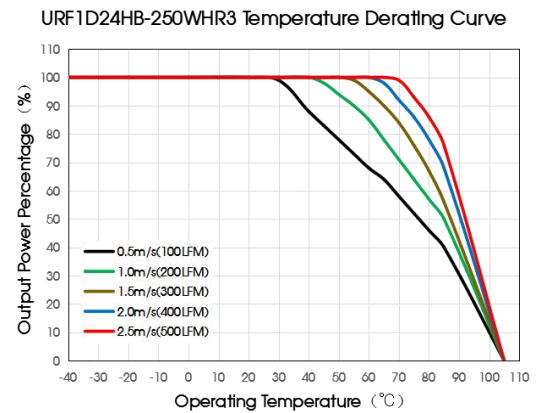
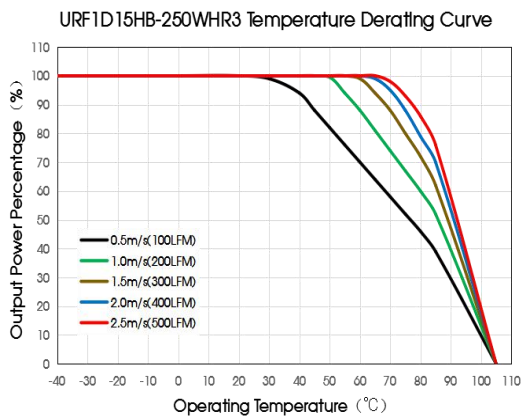
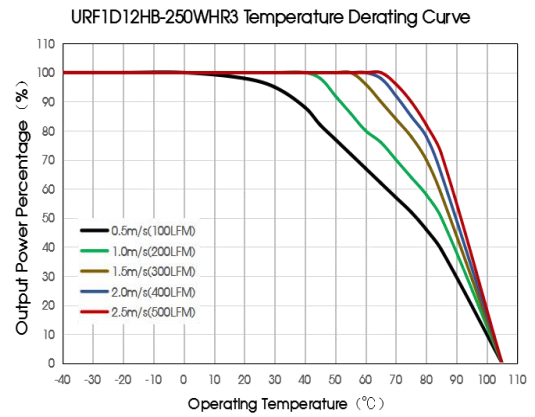
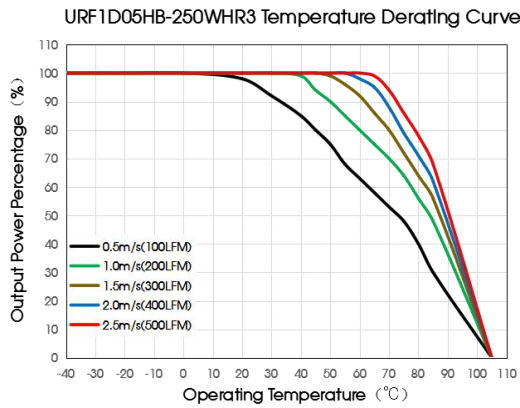

Remote Sense Application

1. Remote Sense Connection if not used

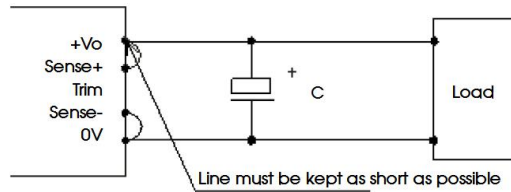

Notes:

- (1) If the sense function is not used for remote regulation the user must connect the +Sense to +Vo and -Sense to 0V at the DC-DC converter pins and will compensate for voltage drop across pins only.
- (2) The connections between Sense lines and their respective power lines must be kept as short as possible, otherwise they may be picking up noise, interference and/or causing unstable operation of the power module.

2. Remote Sense Connection used for Compensation

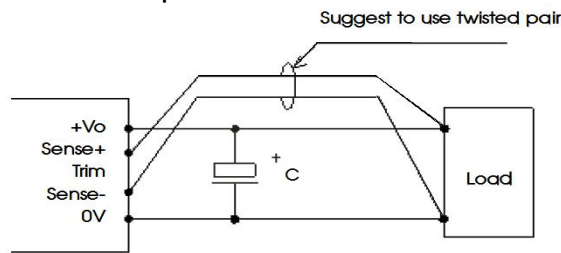

Notes:

- (1) Using remote sense with long wires may cause unstable output, please contact technical support if long wires must be used.
- (2) PCB-tracks or cables/wires for Remote Sense must be kept as short as possible. Twisted pair or shielded wires are suggested for remote compensation and must be kept as short as possible.
- (3) We recommend using adequate cross section for PCB-track layout and/or cables to connect the power supply module to the load in order to keep the voltage drop below 0.3V and to make sure the power supply's output voltage remains within the specified range.
- (4) Note that large wire impedance may cause oscillation of the output voltage and/or increased ripple. Consult technical support or factory for further advice of sense operation.

Design Reference

1. Ripple & noise

All the DC-DC converters of this series are tested before delivery using the recommended circuit shown in Fig. 1.

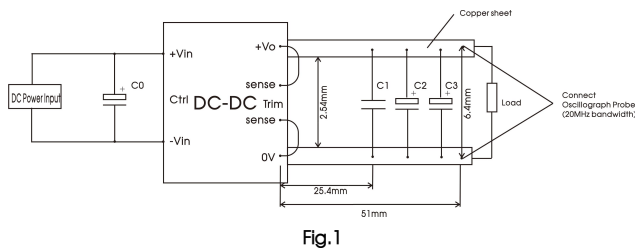

Output voltage	Capacitors value	C0	C1	C2	C3
5VDC	100µF aluminum Electrolytic capacitor (Voltage ≥ 200V)		105K/50V ceramic capacitor	10µF/35V tantalum capacitor	220µF/35V electrolytic capacitor
12VDC					
15VDC					
24VDC					
40VDC					
48VDC					
54VDC			105K/100V ceramic capacitor	--	220µF/100V electrolytic capacitor

Notes: The mounting of A5 no needs C0.

2. Typical application

We recommended using Mornsun's EMC circuit, otherwise please ensure that at least a 100µF electrolytic capacitors is connected at the input in order to ensure adequate voltage surge suppression and protection.

Input and/or output ripple can be further reduced by appropriately increasing the input & output capacitor values Cin and Cout and/or by selecting capacitors with a low ESR (equivalent series resistance). Also make sure that the capacitance is not exceeding the specified max. capacitive load value of the product.



Fig.2

Capacitor Value	Cout	Cin
Output Voltage		
5V/12V/15V/24V/40V/48V/54V	220µF/63V	100 µF/200V

Notes: The mounting of A5 no needs Cin.

3. EMC solution-recommended circuit

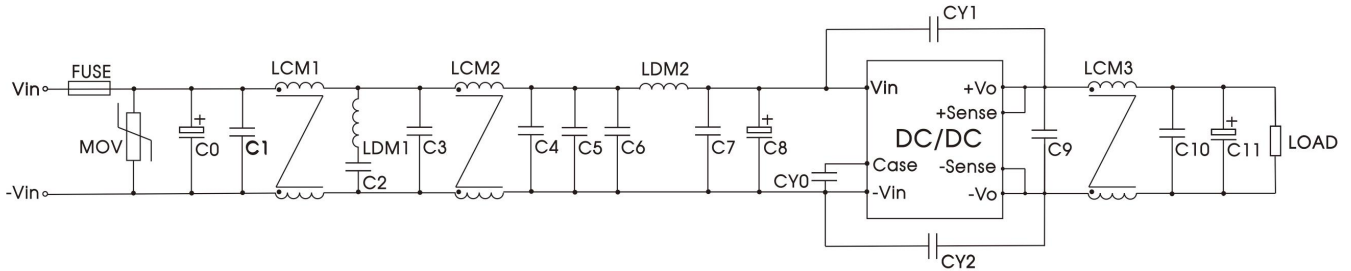
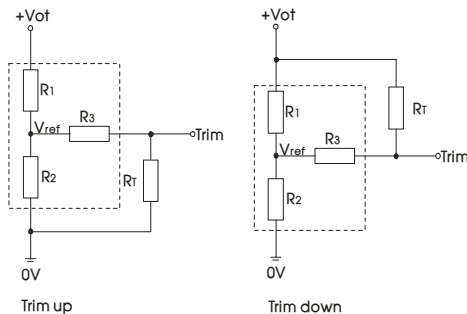

Fig. 3

Components	Recommended Component value
FUSE	Choose according to actual input current
MOV	S20K130 (Varistor)
C0	150µF/400V electrolytic capacitor
C8	100µF/200V electrolytic capacitor
C11	220µF/63V electrolytic capacitor
C1, C2, C3, C4, C5, C6, C7, C9, C10	2.2µF/ 250V ceramic capacitor
LCM1	Mornsun P/N: FL2D-60-402
LCM2	Mornsun P/N: FL2D-60-451
LCM3	Mornsun P/N: FL2D-D0-040
LDM1	0.47uH Shielded inductor
LDM2	2.2uH Shielded inductor
CY0	1nF/400VAC Y1 safety capacitor
CY1	2.2nF/400VAC Y1 safety capacitor
CY2	1nF/400VAC Y1 safety capacitor

4. Trim Function for Output Voltage Adjustment (open if unused)



TRIM resistor connection (dashed line shows internal resistor network)

Calculation formula of Trim resistance:

$$\begin{aligned} \text{up: } R_T &= \frac{\alpha R_2}{R_2 - \alpha} - R_3 & \alpha &= \frac{V_{ref}}{V_o' - V_{ref}} \cdot R_1 \\ \text{down: } R_T &= \frac{\alpha R_1}{R_1 - \alpha} - R_3 & \alpha &= \frac{V_o' - V_{ref}}{V_{ref}} \cdot R_2 \end{aligned}$$

Note: Value for R1, R2, R3, and Vref refer to the above table 1.  
R<sub>T</sub>: Resistance of Trim.  
α: User-defined parameter, no actual meanings.  
V<sub>o</sub>': The trim up/down voltage.

Table 1

Vo Res	5(VDC)	12(VDC)	15(VDC)	24(VDC)	40(VDC)	48(VDC)	54(VDC)
R1(KΩ)	2.92	11	14.49	24.87	48.37	58.69	60.44
R2(KΩ)	2.87	2.87	2.87	2.87	3.21	3.21	2.91
R3(KΩ)	12	17.8	20	20	20	20	17.8
Vref(V)	2.495	2.495	2.495	2.495	2.495	2.495	2.495

- The products do not support parallel connection of their output
- For additional information please refer to DC-DC converter application notes on [www.mornsun-power.com](http://www.mornsun-power.com)

URF1D\_HB-250WR3 Dimensions and Recommended Layout

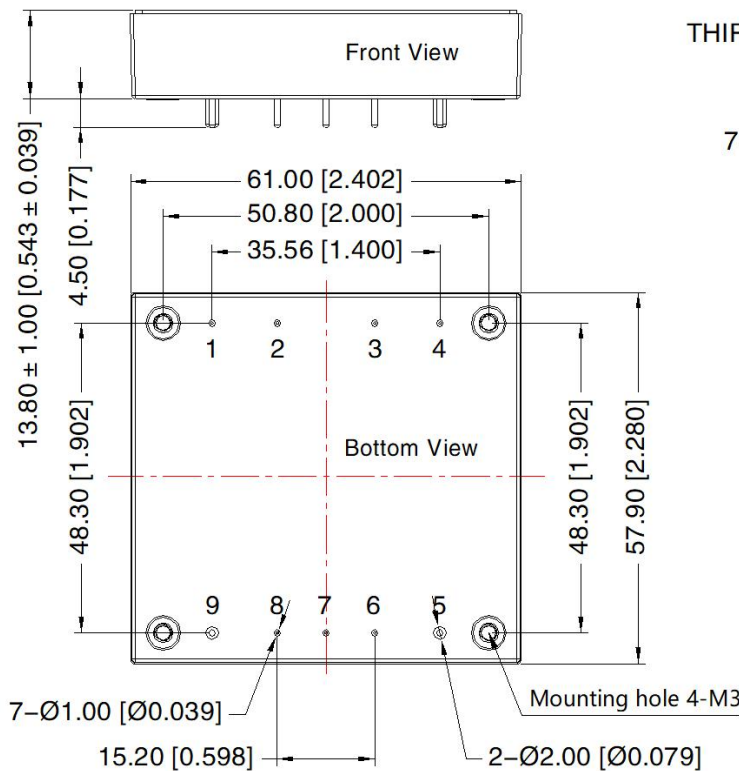

THIRD ANGLE PROJECTION

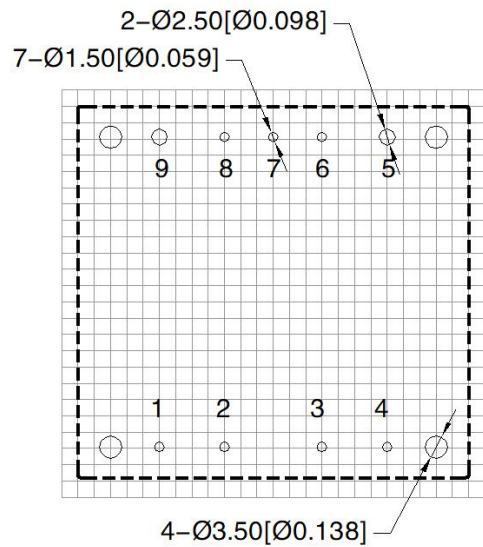

Note: Grid 2.54\*2.54mm

Note:

Unit: mm[inch]

Pin1,2,3,4,6,7,8's diameter: 1.00[0.039]

Pin5,9's diameter: 2.00[0.079]

Pin diameter tolerances: ± 0.10[± 0.004]

General tolerances: ± 0.50[± 0.020]

Mounting hole screwing torque: Max 0.4 N·m

Pin-Out			
Pin	Function	Pin	Mark
1	+Vin	6	Sense-
2	Ctrl	7	Trim
3	Case	8	Sense+
4	-Vin	9	+Vo
5	0V		

URF1D\_HB-250WHR3 Dimensions and Recommended Layout

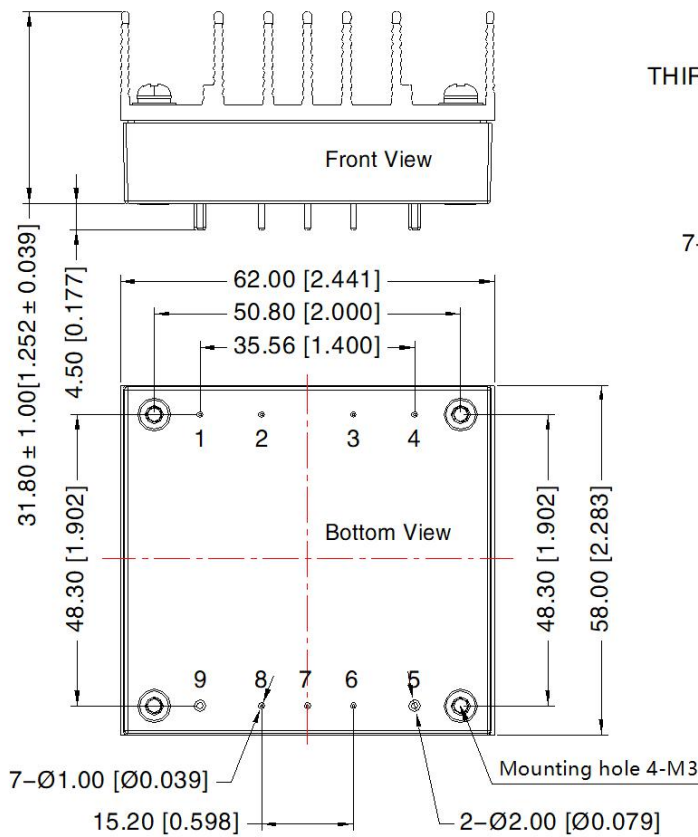

THIRD ANGLE PROJECTION

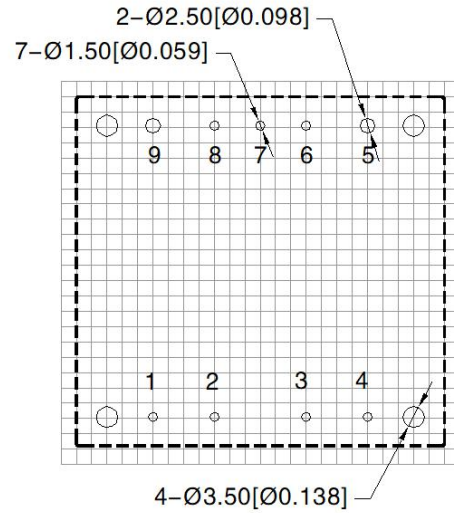

Note: Grid 2.54\*2.54mm

Note:

Unit: mm[inch]

Pin1,2,3,4,6,7,8's diameter: 1.00[0.039]

Pin5,9's diameter: 2.00[0.079]

Pin diameter tolerances: ± 0.10[ ± 0.004]

General tolerances: ± 0.50[ ± 0.020]

Mounting hole screwing torque: Max 0.4 N·m

Pin-Out			
Pin	Function	Pin	Mark
1	+Vin	6	Sense-
2	Ctrl	7	Trim
3	Case	8	Sense+
4	-Vin	9	+Vo
5	0V		



URF1D\_HB-250WR3A5 Dimensions and Recommended Layout

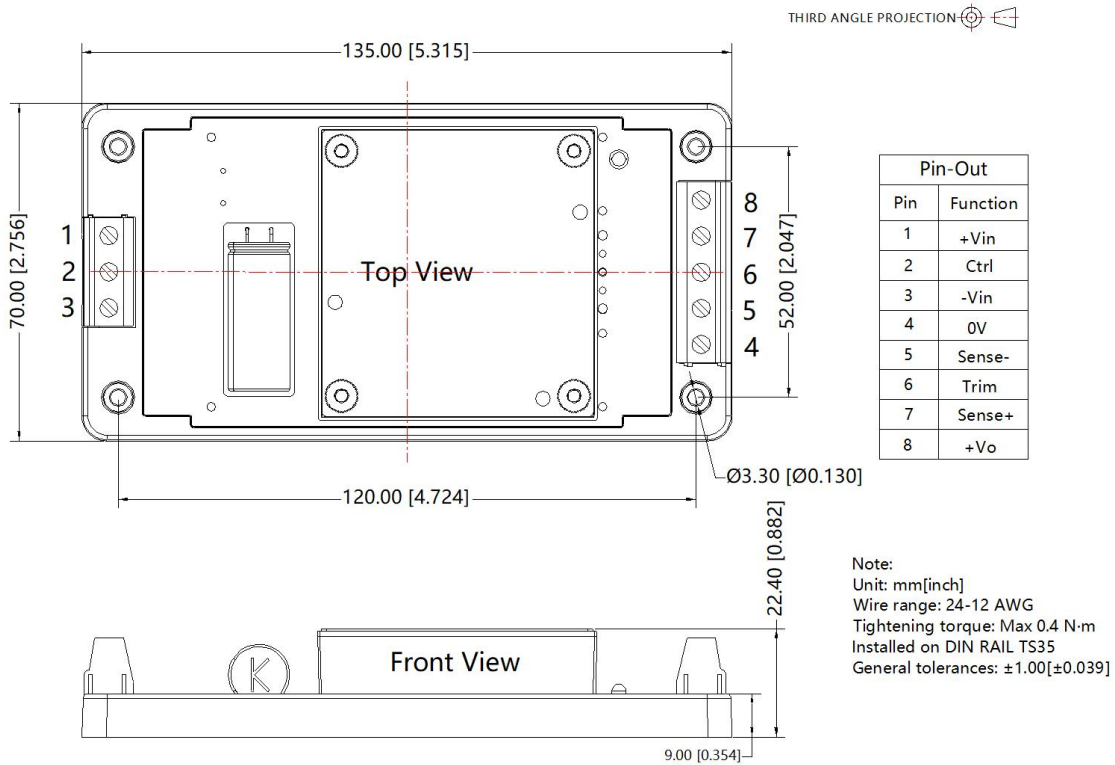

Notes:

1. For additional information on Product Packaging please refer to [www.mornsun-power.com](http://www.mornsun-power.com). Packaging bag number: 58200069 (without heatsink), 58200061 (with heatsink), 58220031(chassis mounting);
2. We suggest to use module at load of over 5%, if not, the ripple of the product may exceeds the specification, but does not affect the reliability of the product;
3. It is recommended that the load imbalance of the dual output is  $\leq \pm 5\%$ . If it exceeds  $\pm 5\%$ , the performance of the product cannot be guaranteed to meet as datasheet marked. For details, please contact our technical staff;
4. The maximum capacitive load offered were tested at input voltage range and full load;
5. Unless otherwise specified, parameters in this datasheet were measured under the conditions of  $T_a=25^\circ\text{C}$ , humidity<75%RH with nominal input voltage and rated output load;
6. All index testing methods in this datasheet are based on company corporate standards;
7. We can provide product customization service, please contact our technicians directly for specific information;
8. Products are related to laws and regulations: see "Features" and "EMC";
9. Our products shall be classified according to ISO14001 and related environmental laws and regulations, and shall be handled by qualified units.

Mornsun Guangzhou Science & Technology Co., Ltd.

Address: No. 5, Kehui St. 1, Kehui Development Center, Science Ave., Guangzhou Science City, Huangpu District, Guangzhou, P. R. China  
Tel: 86-20-38601850 Fax: 86-20-38601272 E-mail: [info@mornsun.cn](mailto:info@mornsun.cn) [www.mornsun-power.com](http://www.mornsun-power.com)