

NACL1000Q-S3/SP1N(NT1000C-S/SP3)电流传感器 Current Transducer

版本: B

产品说明

Applications

NACL1000Q-S3/SP1N 磁平衡霍尔电流传感器适用于对交流、直流、脉冲电流的隔离精确测量，测量时一次侧与二次侧间完全绝缘。

For the electronic measurement of currents: AC, DC, pulsed..., with galvanic separation between the primary circuits and the secondary circuits.



产品优点 Advantages	产品应用 Applications	参照标准 Standards
高精度 Excellent accuracy	交流变频器 AC variable speed drives	GB/T 25119-2010 EN50178 EN50155
线性度好 Very good linearity	私服电机驱动 Servo motor drives	
低温漂 Low temperature drift	电池供电 Battery supplied applications	
宽频带 Wide frequency bandwidth	变流器/逆变器 converter /inverter	
快速响应 Optimized response time	UPS/SVG	

主要电气参数 Main electrical data

 (@ ±I_{PN}, T_A = 25°C)

额定测量电流 I _{PN}	Primary nominal current	1000A
测量范围 I _{PM}	Primary current measuring range	±2400A
电源电压 V _C	Supply voltage	DC ±(15~24)×(1±5%)V
电流消耗 I _C (@±24V)	Current consumption	≤ ±30mA+I _{SN}
额定测量输出 I _{SN}	Output current	200mA
匝比	Conversion ratio	1:5000
负载电阻 R _M	Load resistance	@ ±15V, ±1000A: 0~15Ω @ ±15V, ±1200A: 0~7Ω @ ±24V, ±1000A: 0~50Ω @ ±24V, ±2000A: 0~7Ω

精度 - 动态参数 Accuracy - Dynamic performance data

基本误差 δ _i (@I _{PN} , T _A =25°C)	Overall Accuracy	≤ ±0.4%
线性度 δ _L (@I _{PN} , T _A =25°C)	Linearity error	≤ ±0.1%
零点输出电流 I _O (@I _p =0, T _A = 25°C)	Offset current	≤ ±0.5mA
零点温度漂移 I _{OT}	Temperature coefficient of δ _{Zt}	≤ ±1.0mA
响应时间 T _R (90% of I _{PN} & di/dt > 50 A/μS)	Step response time to 90 % of I _{PN}	≤ 1μS

一般数据 General data

工作温度 Ta	Ambient operating temperature	-40~+85℃
储存温度 Ts	Ambient storage temperature	-45~+90℃
重量 m	Mass	≤900g

绝缘耐压 Insulation coordination

耐压	Voltage for AC insulation test, 50Hz,1min	13.4kV
----	---	--------

NACL.1000Q-S3/SP1N 电流传感器外形图 Dimensions NACL.1000Q-S3/SP1N Series (in mm)

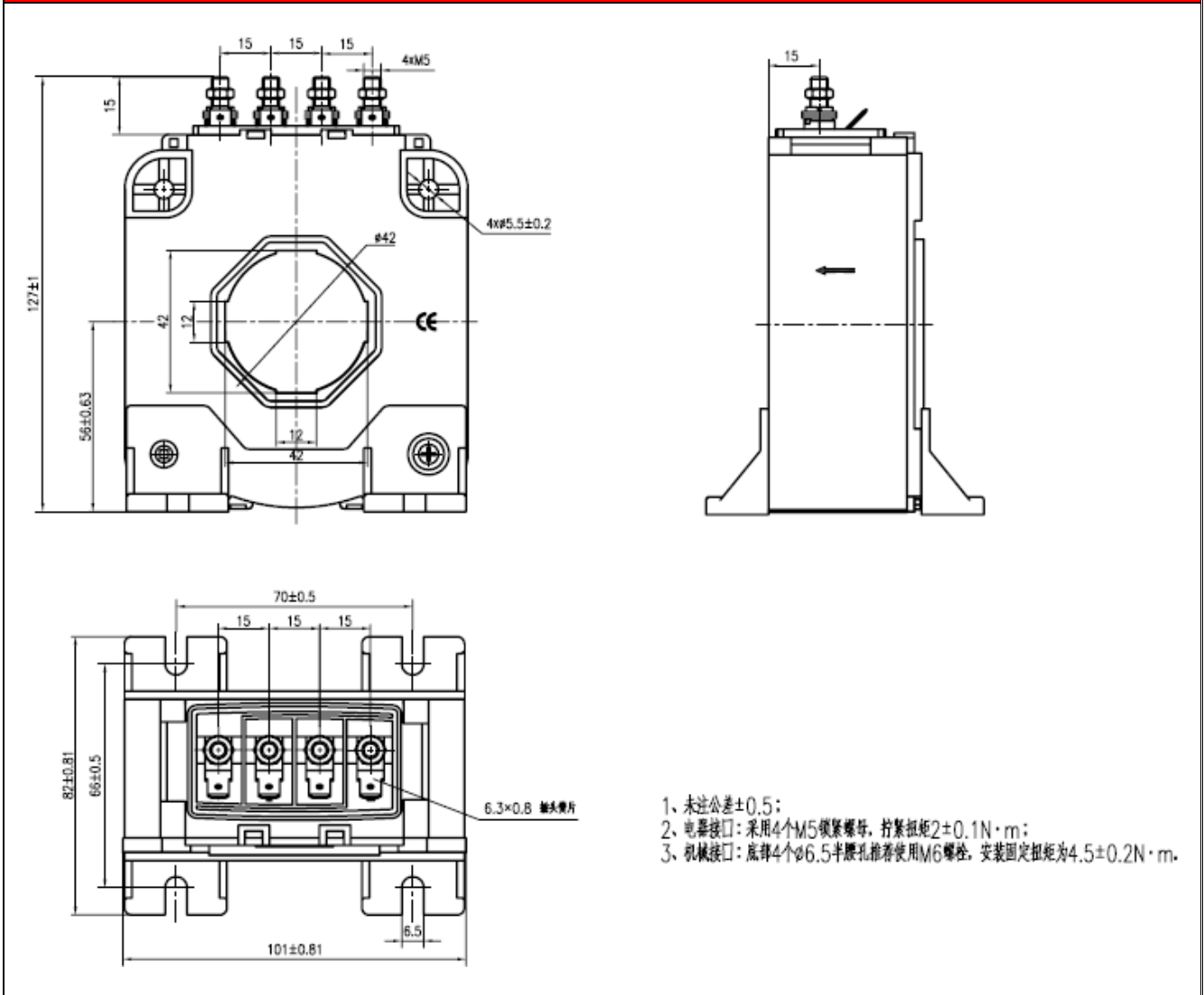

电气连接 Connection

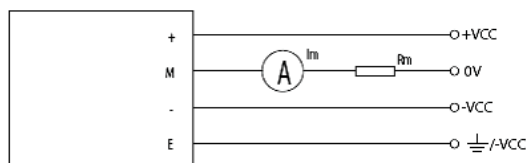

机械特征 Mechanical characteristics

备注 Remark

<p>1. 传感器安装孔径: $4 \times \phi 5.5\text{mm}$ Sensors installed aperture: $4 \times \phi 5.5 \text{ mm}$</p>	<p>1. 当测量电流方向与传感器上标示的  方向一致时, 传感器输出 I_{SN} 为正。When measuring the current direction of arrow mark on direction and sensor, the sensor output I_{SN} is positive.</p>
<p>2. 推荐使用: M5 螺栓固定 It is recommended to use: M5 bolt</p>	<p>2. 产品二次侧连接线优选屏蔽线, 屏蔽层接近产品端连接线可接机壳, 负电源或电源 0V。Product secondary side connecting line optimization shielding wire, cable shielding layer close to the product end can connect chassis, negative power or power 0 v.</p>
<p>3. 安装固定力矩: $3.5\text{N} \cdot \text{m}$ The installation of fixed torque: $3.5 \text{ N} \cdot \text{m}$</p>	<p>3. 电量传感器安装螺钉孔的垂直度要求: 要求在国家标准 8 级或以上 (或 0.06 以下)。Power sensor mounting screw hole of the vertical degree requirements: requirements in the national standard grade 8 or above (or below 0.06).</p>
<p>4. 原边通孔: $\phi 42\text{mm}$ The original hole: $\phi 42\text{mm}$</p>	<p>4. 电量传感器安装面平面度要求: Sensor mounting surface flatness requirements: (a).大平面安装平面度国家标准 11 级或以上 (或平面起伏小于 0.25mm); Planeness national standard installation grade 11 or above (or surface fluctuation is less than 0.25 mm); (b).安装面加有小圆凸台设计时平面度要求达国家标准 12 级或以上 (或平面起伏小于 0.5mm); When mounting surface with a small round convex platform design flatness requirement of national standard grade 12 or more (or less than 0.5 mm) in plane ups and downs;</p>
<p>5. 次边电气连接: M5 的螺栓 (或 6.3×0.8 的插头簧片) $2.2\text{N} \cdot \text{m}$ Electrical connections: The plug of the M5 bolt (or 6.3×0.8 reed) $2.2\text{N} \cdot \text{m}$</p>	<p>5. 未注公差 $\pm 0.5\text{mm}$; Did not note the tolerance $+ / - 1\text{mm}$;</p>