

Wide input voltage Non-isolated and Regulated Single Output

FEATURES



- High efficiency up to 95%
- No-load input current as low as 0.2mA
- Operating ambient temperature range -40°C to +85°C
- Output short-circuit protection
- SMD package
- EN62368 Approval

K78_T-1000R3 series are high efficiency switching regulators. The converters feature high efficiency, low loss and short circuit protection in a compact SMD package. These products are widely used in applications such as industrial control, instrumentation and electric power.

Selection Guide

Certification	Part No.	Input Voltage (VDC)*	Output		Full Load Efficiency (%) Vin Min. / Vin Max.	Max. Capacitive Load (µF)
		Nominal (Range)	Voltage (VDC)	Current (mA) Max.		
CE	K7801T-1000R3	12 (4.75-32)	1.5	1000	76/66	680
	K78X2T-1000R3	12 (4.75-32)	1.8	1000	79/69	680
	K7802T-1000R3	12 (4.75-32)	2.5	1000	86/74	680
	K7803T-1000R3	24 (6.5-36)	3.3	1000	90/80	680
	K7805T-1000R3	24 (8-36)	5	1000	93/85	680
	K78X6T-1000R3	24 (10-36)	6.5	1000	93/86	680
	K7809T-1000R3	24 (13-36)	9	1000	94/89	680
	K7812T-1000R3	24 (16-36)	12	800	95/92	680

Note:*For input voltage exceeding 30 VDC, an input capacitor of 22µF/50V is required.

Input Specifications

Item	Operating Conditions	Min.	Typ.	Max.	Unit
No-load Input Current		--	0.2	1	mA
Reverse Polarity at Input		Avoid / Not protected			
Input Filter		Capacitance filter			
Ctrl*	Module on	Open or pulled high (TTL level 3.2-5.5VDC)			
	Module off	Pulled low to GND level (0-0.8VDC)			
	Input current when off	--	0.2	1	mA

Output Specifications

Item	Operating Conditions	Min.	Typ.	Max.	Unit	
Voltage Accuracy	Full load, input voltage range	1.5/1.8/2.5/3.3VDC output	--	±2	±4	%
		Others	--	±2	±3	
Linear Regulation	Full load, input voltage range	1.5/1.8/2.5VDC output	--	±0.3	±0.6	
		Others	--	±0.2	±0.4	

Load Regulation	Nominal input voltage, 10% -100% load	1.5/1.8/2.5VDC output	--	0.8	±1.5	%
		Others	--	0.3	±0.6	
Ripple & Noise*	20MHz bandwidth		--	30	75	mVp-p
Temperature Coefficient	Operating temperature range -40°C to +85°C		--	--	±0.03	%/°C
Transient Response Deviation	Nominal input voltage, 25% load step change		--	50	150	mV
Transient Recovery Time			--	0.2	1	ms
Short-circuit Protection	Nominal input		Continuous, self-recovery			
Vadj	Input voltage range		--	±10	--	%Vo
Note: *						
① The "parallel cable" method is used for ripple and noise test, please refer to DC-DC Converter Application Notes for specific information;						
② With light loads at or below 20%, Ripple & Noise increases to 150mVp-p max.						

General Specifications

Item	Operating Conditions	Min.	Typ.	Max.	单位	
Operating Temperature	See Fig. 1	-40	--	+85	°C	
Storage Temperature		-55	--	+125		
Storage Humidity	Non-condensing	5	--	95	%RH	
Reflow Soldering Temperature		Peak temperature ≤245°C, duration ≤60s max. over 217°C. Also refer to IPC/JEDEC J-STD-020D.1.				
Switching Frequency	Full load, nominal input	1.5/1.8/2.5VDC output	--	370	--	KHz
		3.3/5/6.5VDC output	--	520	--	
		09/12VDC output	--	700	--	
MTBF	MIL-HDBK-217F@25°C	2000	--	--	K hours	

Mechanical Specifications

Case Material	Black plastic; flame-retardant and heat-resistant (UL94 V-0)
Dimensions	15.24 x 11.40 x 8.25 mm
Weight	1.7g (Typ.)
Cooling Method	Free air convection

Electromagnetic Compatibility (EMC)

Emissions	CE	CISPR32/EN55032	CLASS B (see Fig. 4-② for recommended circuit)	
	RE	CISPR32/EN55032	CLASS B (see Fig. 4-② for recommended circuit)	
Immunity	ESD	IEC/EN 61000-4-2	Contact ±4KV	perf. Criteria B
	RS	IEC/EN 61000-4-3	10V/m	perf. Criteria A
	EFT	IEC/EN 61000-4-4	±1KV (see Fig. 4-① for recommended circuit)	perf. Criteria B
	Surge	IEC/EN 61000-4-5	line to line ±1KV (see Fig. 4-① for recommended circuit)	perf. Criteria B
	CS	IEC/EN 61000-4-6	3Vr.m.s	perf. Criteria A

Typical Characteristic Curves

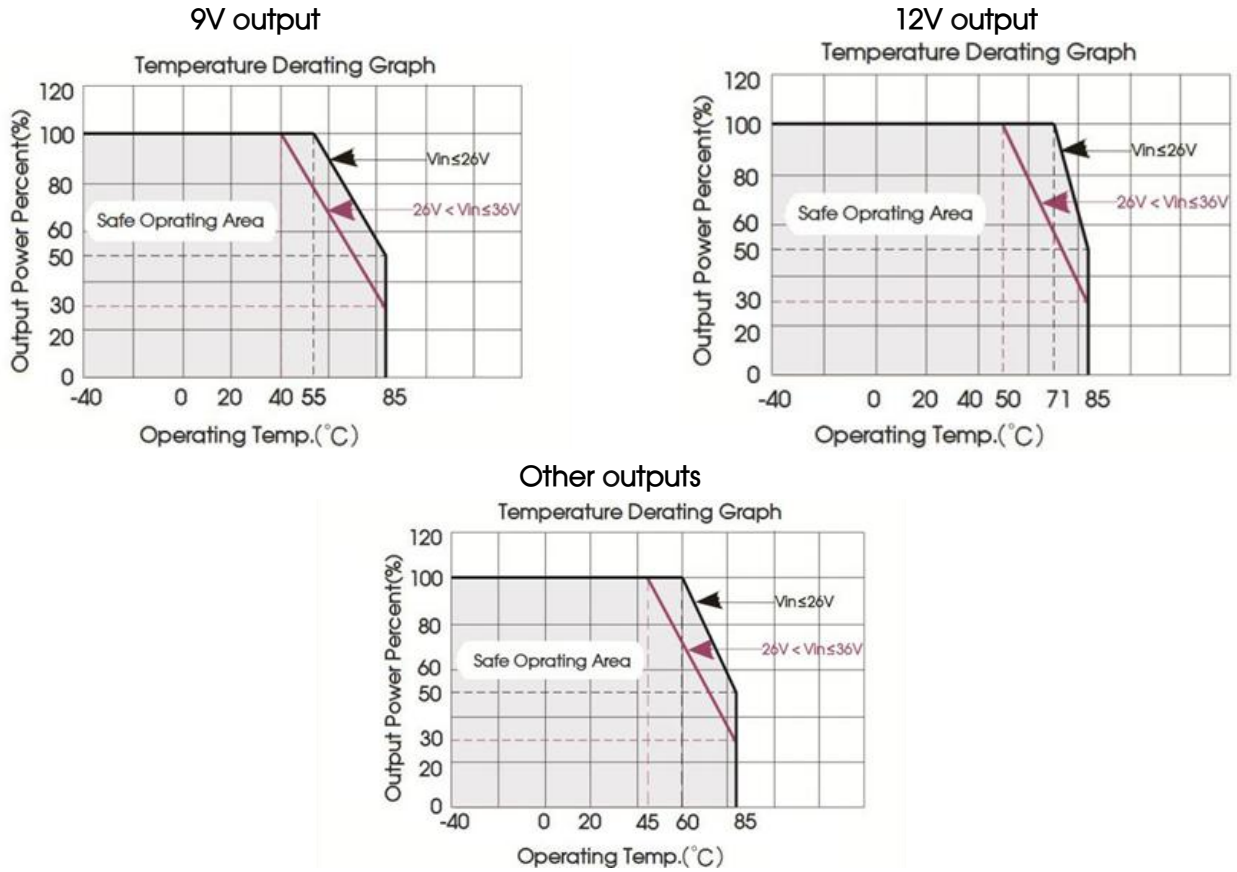
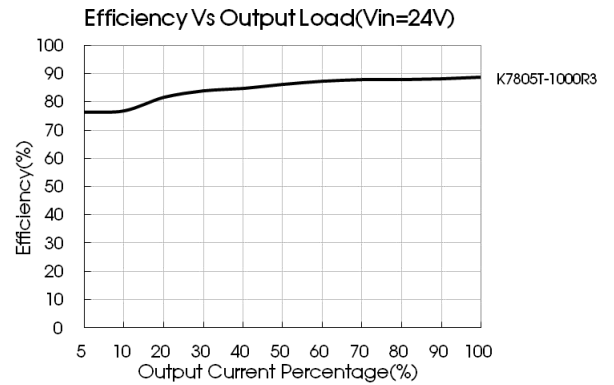
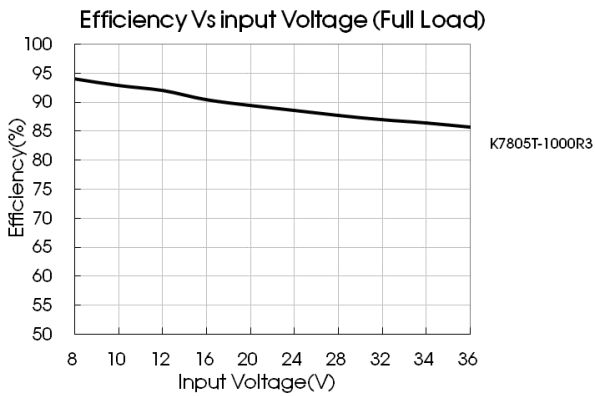

Fig. 1



Design Reference

1. Typical application

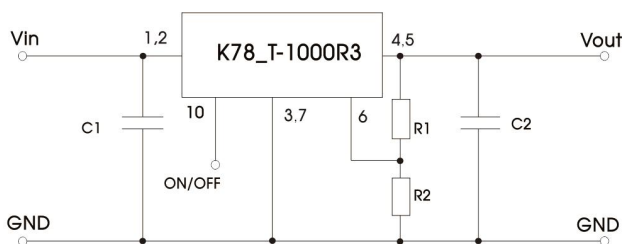

Fig. 2 Typical application circuit

Part No.	C1 (ceramic capacitor)	C2 (ceramic capacitor)	Ra1/Ra2 (Vadj resistance)
K7801T-1000R3	10μF/50V	22μF/10V	Refer to Vadj resistance calculation
K78X2T-1000R3		22μF/10V	
K7802T-1000R3		22μF/10V	
K7803T-1000R3		22μF/10V	
K7805T-1000R3		22μF/16V	
K78X6T-1000R3		22μF/16V	
K7809T-1000R3		22μF/16V	
K7812T-1000R3		22μF/25V	

table 1

- Note:
1. The required C1 and C2 capacitors must be connected as close as possible to the terminals of the module.
 2. Refer to Table 1 for C1 and C2 capacitor values. For certain applications, increased values and/or tantalum or low ESR electrolytic capacitors may also be used instead.
 3. Converter cannot be used for hot swap and with output in parallel.
 4. To further reduce the output ripple and noise, we suggested the use of a "LC" filter at the output terminals, with an inductor value (L) of 10μH-47μH.

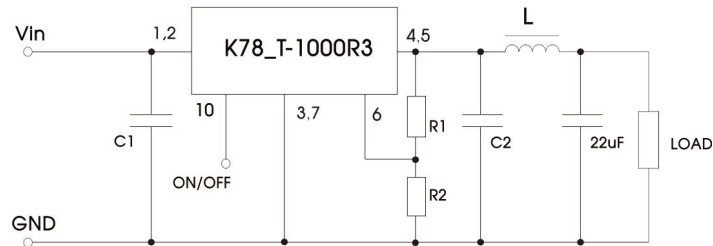

Fig. 3 External "LC" output filter circuit diagram

2. EMC compliance circuit

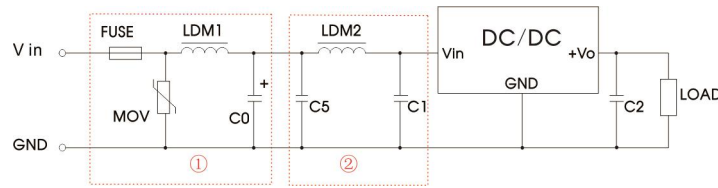
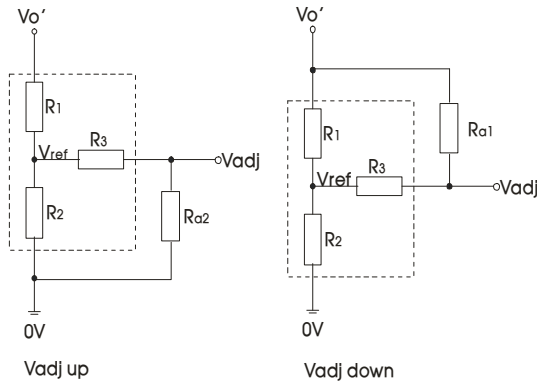

Fig.4 Recommended compliance circuit

FUSE	MOV	LDM1	C0	C2	C1/C5	LDM2
Select fuse value according to actual input current	S20K30	82μH	680μF /50V	Refer to table 1	4.7μF /50V	68μH

Note: Part ① in Fig. 4 shows EMS compliance filter and part ② filter for EMI compliance; depending on requirement both filters ① and ② can be used in series as shown.

3. Trim Function for Output Voltage Adjustment (open if unused)



Calculating Trim resistor values:

$$\text{up: } R_{a2} = \frac{\alpha R_2}{R_2 - \alpha} - R_3$$

$$\alpha = \frac{V_{ref}}{V_{o'} - V_{ref}} \cdot R_1$$

$$\text{down: } R_{a1} = \frac{\alpha R_1}{R_1 - \alpha} - R_3$$

$$\alpha = \frac{V_{o'} - V_{ref}}{V_{ref}} \cdot R_2$$

Ra1、Ra2= Trim Resistor value;
α= self-defined parameter;
Vo'=desired output voltage.

Fig.5 Circuit diagram of Vadj up and down (dashed line shows internal part of module)

Vout(V)	R1(KΩ)	R2(KΩ)	R3(KΩ)	Vref(V)
1.5	7.5	7.5	15	0.75
1.8	4.7	3.3	6.8	0.75
2.5	9.1	3.9	8.2	0.75
3.3	75	22	75	0.75
5	43	7.5	33	0.75
6.5	43	5.6	22	0.75
9	43	3.9	22	0.75
12	36	2.4	10	0.75

Note: The 1.5V model's output voltage can only be adjusted up (Vadj up) and cannot be adjusted to a lower voltage (Vadj down is not applicable).

4. For additional information please refer to DC-DC converter application notes on www.mornsun-power.com

Dimensions and Recommended Layout

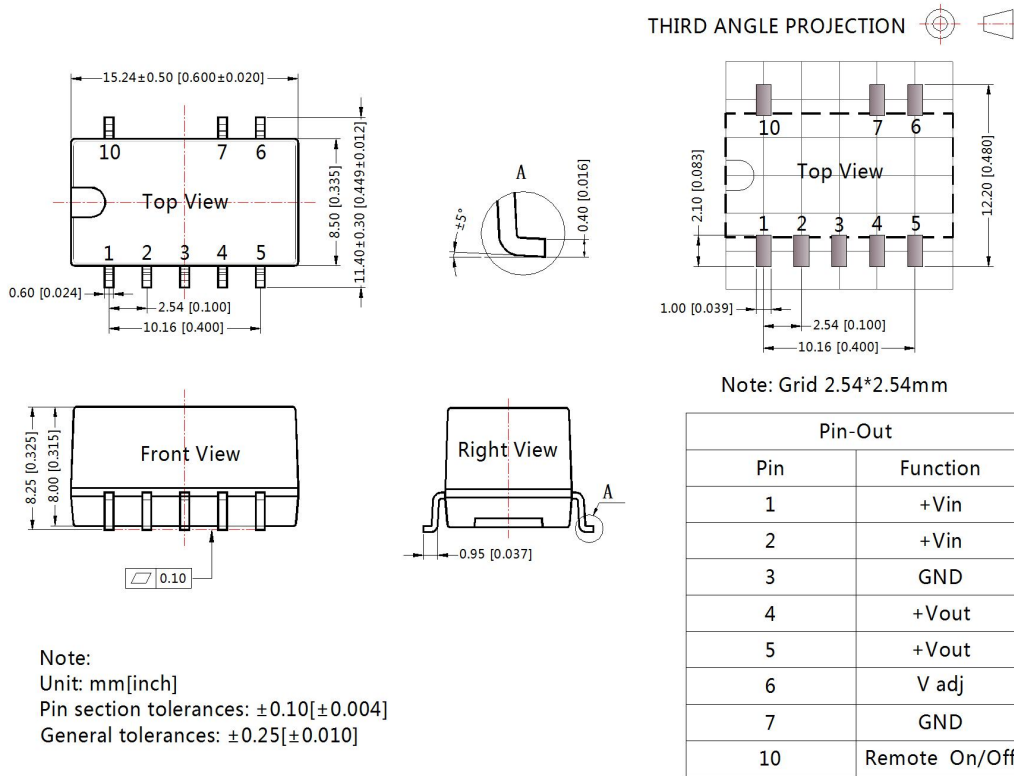

NC: Pin to be isolated from circuitry

Notes:

- For additional information on Product Packaging please refer to www.mornsun-power.com. Tube Packaging bag number: 58210057, Roll packaging bag number: 58210058;
- The max. capacitive load should be tested within the input voltage range and under full load conditions;
- Unless otherwise specified, data in this datatable should be tested under the conditions of $T_a=25^{\circ}\text{C}$, humidity<75%RH when inputting nominal voltage and outputting rated load;
- All index testing methods in this datatable are based on our Company's corporate standards;
- The performance indexes of the product models listed in this manual are as above, but some indexes of non-standard model products will exceed the above-mentioned requirements, and please directly contact with our technician for specific information;
- Products are related to laws and regulations: see "Features" and "EMC";
- Our products shall be classified according to ISO14001 and related environmental laws and regulations, and shall be handled by qualified units.

MORNSUN Guangzhou Science & Technology Co., Ltd.

Address: No. 5, Kehui St. 1, Kehui Development Center, Science Ave., Guangzhou Science City, Luogang District, Guangzhou, P. R. China
Tel: 86-20-38601850 Fax: 86-20-38601272 E-mail: sales@mornsun.cn www.mornsun-power.com