

**NV100-2000V/SP7 电压传感器 Voltage Transducer**

版本: A

**产品说明**
**Applications**

该磁平衡式电压传感器适用于对交流、直流和脉动电压的隔离精确测量，测量时一次侧与二次侧之间完全绝缘。

For the electronic measurement of voltages: AC, DC IMPL., etc., with galvanic isolation between the primary (high power) and the secondary (electronic) circuits.



产品优点 Advantages	产品应用 Applications	参照标准 Standards
高精度 Excellent accuracy	交流变频器 AC variable speed drives	EN50155
线性度好 Very good linearity	电池供电 Battery supplied applications	
低温漂 Low temperature drift	变流器/逆变器 converter /inverter	
宽频带 Wide frequency bandwidth	UPS/SVG	
快速响应 Optimized response time		

**主要电气参数 Main electrical data**

额定测量电压 $V_{PN}$ (V)	Primary nominal voltage rms	2000
测量范围 $V_P$ (V)	Primary voltage measuring range	0~±3000
电源电压 $V_C$ (V)	Supply voltage	DC±(15~24)×(1±10%)V
额定测量输出 $I_{SN}$ (mA)	Secondary nominal current rms	50mA
测量电阻 $R_M$ (Ω)	Measuring resistance	1000V: 0Ω ~ 100Ω (@ ±15V) 1000V: 60Ω ~ 200Ω (@ ±24V)
二次侧电流消耗 $I_C$ (@±24V)	Current consumption	≤30mA+ Secondary output current $I_{SN}$
隔离耐压	Isolation test: Between the primary circuit to the secondary circuit	9kVrms/50Hz/1min

**精度 - 动态参数 Accuracy - Dynamic performance data**

基本误差 $\delta_i$ (@ $I_{PN}$ , $T_A=25^\circ\text{C}$ )	Overall Accuracy	≤±0.7%
线性度误差 $\delta_L$ (@ $I_{PN}$ , $T_A=25^\circ\text{C}$ )	Linearity error	<0.1%
零点输出电流 $I_O$ (@ $I_P=0$ , $T_A=25^\circ\text{C}$ )	Offset current	≤±0.2mA
零点温漂 IOT	Thermal drift	≤±0.8mA (-40°C~+85°C)
响应时间 $t_r$	Response time to 90% of $I_{PN}$ step	≤60us

**一般数据 General data**

工作温度 $T_a$	Ambient operating temperature	-40°C~+85°C
储存温度 $T_s$	Ambient storage temperature	-45°C~+90°C
重量 $m$	Mass	≤850g

外形图 Dimensions (in mm)

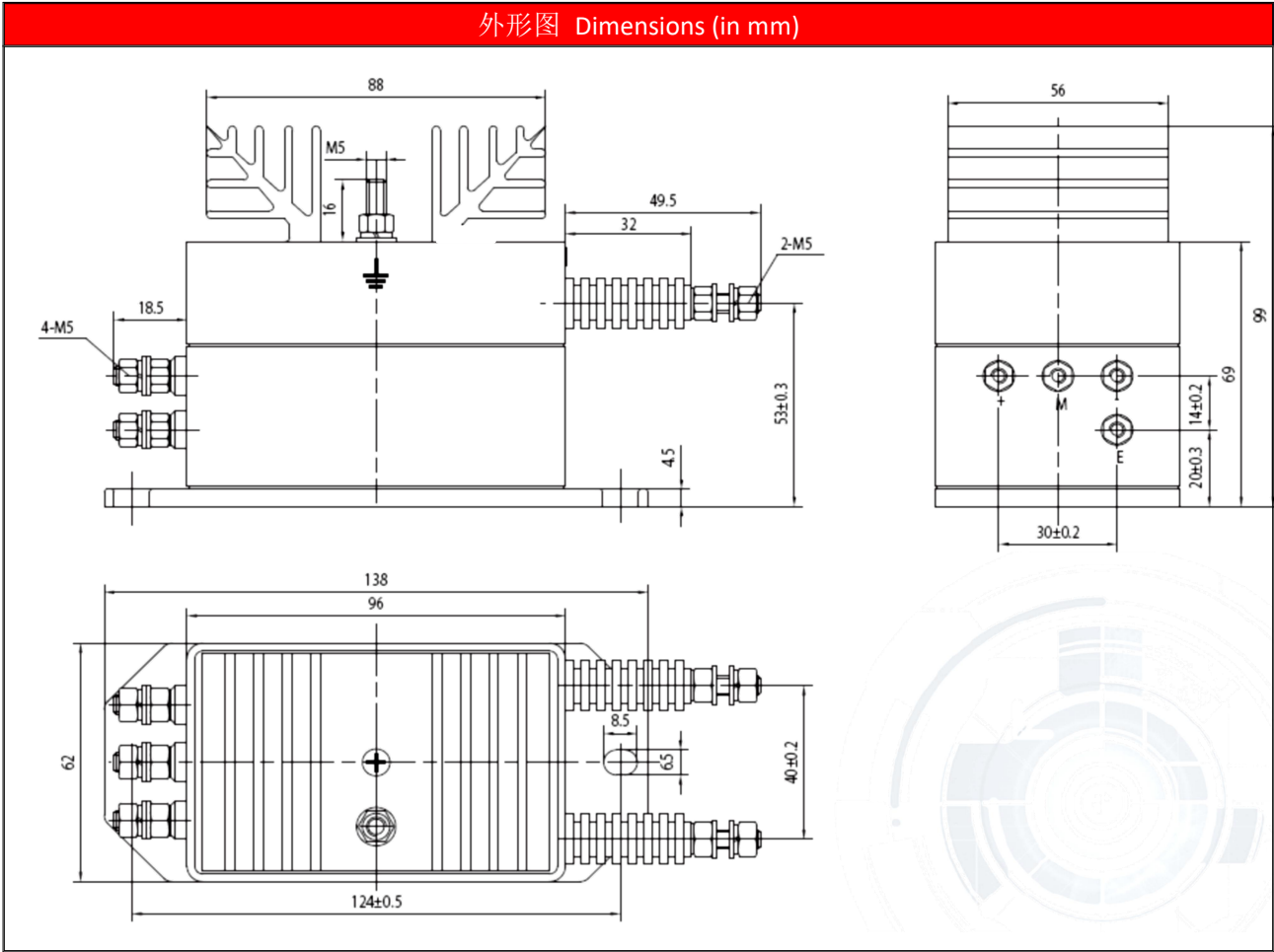

电气连接 Connection

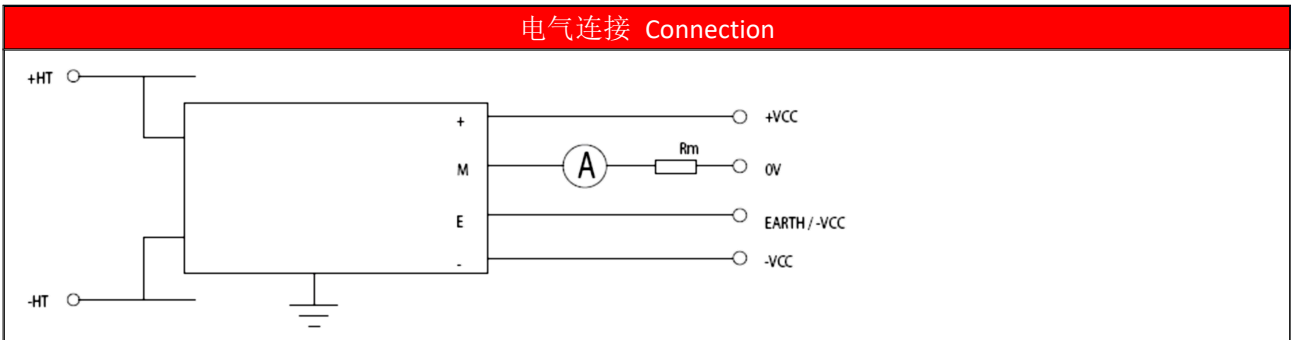

机械特征 Mechanical characteristics		备注 Remark
未注公差 General tolerance	± 1 mm	1. +HT 接测量电压为正时，传感器输出 $I_{SN}$ 为正。IS is positive When a positive voltage is applied on +HT 2. 产品二次侧连接线优选屏蔽线，屏蔽层接近产品端连接线可接机壳，负电源或电源 0V。Product secondary side connecting line optimization shielding wire, cable shielding layer close to the product end can connect chassis, negative power or power 0 v. 3. 电量传感器安装螺钉孔的垂直度要求：要求在国家标准 8 级或以上（或 0.06 以下）。Power sensor mounting screw hole of the vertical degree requirements: requirements in the national standard grade 8 or above (or below 0.06). 4. 电量传感器安装面平面度要求：Sensor mounting surface flatness requirements: (a).大平面安装平面度国家标准 11 级或以上（或平面起伏小于 0.25mm）； Planeness national standard installation grade 11 or above (or surface fluctuation is less than 0.25 mm); (b).安装面加有小圆凸台设计时平面度要求达国家标准 12 级或以上（或平面起伏小于 0.5mm）； When mounting surface with a small round convex platform design flatness requirement of national standard grade 12 or more (or less than 0.5 mm) in plane ups and downs; 5. 未注公差 ± 1mm; Did not note the tolerance + / - 1 mm;
传感器安装方式一(推荐) Transducer fastening (Recommended) 力矩 fastening torque	2 hole $\phi$ 6.5mm 2 M6 steel screws 4.5N	
原边电气连接 Primary connection	M5 steel screws 2.2N	
次边电气连接 Secondary connection	M5 steel screws 2.2N	