

100W isolated DC-DC converter
Ultra-wide input and regulated single output



Patent Protection RoHS



FEATURES

- Ultra-wide input voltage range: 66-160VDC
- High efficiency up to 88%
- Low no-load power consumption
- Reinforced insulation, input - output isolation test voltage: 3k VAC, input - case isolation test voltage: 2.1k VAC
- Operating ambient temperature range: -40°C to +105°C
- Input under-voltage protection, output short-circuit, over-current, over-voltage, over-temperature protection
- Industry standard 1/4 brick
- Meets EN50155 standards

URF1D28QB-100WR3 is a high-performance product specifically designed for a variety of railway applications. The DC-DC converters feature 100W output power with no requirement for minimum load, wide input voltage from 66-160VDC, and allowing operating temperature as high as 105°C. The products also provide input under-voltage protection, output over-voltage, short-circuit and over-temperature protection. Additional functions include remote On/Off control, remote sense compensation and output voltage trim adjustment. Meets EN50155 standards and they are widely used in railway systems and associated equipment.

Selection Guide

Certification	Part No.	Input Voltage (VDC)		Output		Full Load Efficiency ^② (%) Min./Typ.	Max. Capacitive Load(μF)
		Nominal (Range)	Max. ^①	Voltage (VDC)	Current (mA) Max./Min.		
--	URF1D28QB-100WR3	110 (66-160)	170	28	3571/0	86/88	3000

Note: ① Exceeding the maximum input voltage may cause permanent damage;
② Efficiency is measured in nominal input voltage and rated output load.

Input Specifications

Item	Operating Conditions	Min.	Typ.	Max.	Unit
Input Current (full load / no-load)	Nominal input voltage	--	1033/10	1057/25	mA
Reflected Ripple Current		--	100	--	
Surge Voltage (1sec. max.)		-0.7	--	180	VDC
Start-up Voltage		--	--	66	
Under-voltage Protection		60	--	--	
Input Filter		Pi filter			
Hot Plug		Unavailable			
Ctrl*	Module on	Ctrl pin open or pulled high (3.5-12VDC)			
	Module off	Ctrl pin -Vin or pulled low (0-1.2VDC)			
	Input current when off	--	2	10	mA

Note: *The Ctrl pin voltage is referenced to input -Vin.

Output Specifications

Item	Operating Conditions	Min.	Typ.	Max.	Unit
Voltage Accuracy	Nominal input voltage, 0%-100% load	--	±1	±3	%
Linear Regulation	Input voltage variation from low to high at full load	--	±0.1	±0.3	
Load Regulation	Nominal input voltage, 10%-100% load	--	±0.3	±0.5	
Transient Recovery Time	25% load step change	--	200	500	μs
Transient Response Deviation		--	±3	±5	%
Temperature Coefficient	Full load	--	--	±0.03	%/°C

Ripple & Noise *	20MHz bandwidth, 10%lo-100%lo load	--	100	200	mVp-p
Trim		90	--	110	%
Output Voltage Remote Compensation(sense)		--	--	105	
Over-temperature Protection	Surface max. temperature	--	110	--	°C
Over-voltage Protection	Input voltage range	110	--	140	%Vo
Over-current Protection	Input voltage range	110	140	190	%Io
Short-circuit Protection		Hiccup, continuous, self-recovery			

Note: *Ripple & Noise at 0%lo-100%lo load \leq 300mV, the measuring method of ripple and noise, please refer to Fig. 1 .

General Specifications

Item	Operating Conditions	Min.	Typ.	Max.	Unit
Isolation	Input-output	3000	--	--	VAC
	Input-case				
	Output-case	1500	--	--	VDC
Insulation Resistance	Input-output resistance at 500VDC	1000	--	--	MΩ
Isolation Capacitance	Input-output capacitance at 100KHz/0.1V	--	2200	--	pF
Switching Frequency	PFM mode	--	170	--	KHz
MTBF	MIL-HDBK-217F@25°C	500	--	--	K hours

Environmental Specifications

Item	Operating Conditions	Min.	Typ.	Max.	Unit
Operating Temperature Range	See temperature derating curves	-40	--	+105	°C
Storage Humidity	Non-condensing	5	--	95	%RH
Storage Temperature		-55	--	+125	°C
Pin Soldering Resistance Temperature	Soldering spot is 1.5mm away from case for 10 seconds	--	--	+300	
Cooling Test		EN60068-2-1			
Dry Heat		EN60068-2-2			
Damp Heat		EN60068-2-30			
Shock and Vibration Test		IEC/EN61373 - Category 1, Grade B			

Mechanical Specifications

Case Material	Aluminum alloy case; Black plastic bottom, flame-retardant and heat-resistant (UL94 V-0)
Dimensions	60.80 x 39.20 x 12.70mm
Weight	78.0g(Typ.)
Cooling Method	Free air convection or forced convection

Electromagnetic Compatibility (EMC)

Emissions	CE	CISPR32/EN55032	150KHz-30MHz	Class B (see Fig. 3 for recommended circuit)	
	RE	CISPR32/EN55032	30MHz-1GHz	Class B (see Fig. 3 for recommended circuit)	
Immunity	ESD	IEC/EN61000-4-2	GB/T17626.2	Contact \pm 6KV, Air \pm 8KV	perf.Criteria A
	RS	IEC/EN61000-4-3	GB/T17626.3	20V/m	perf.Criteria A
	CS	IEC/EN61000-4-6	GB/T17626.6	10Vr.m.s	perf.Criteria A
	EFT	IEC/EN61000-4-4	GB/T17626.4	\pm 2KV (5KHz, 100KHz) (see Fig. 3 for recommended circuit)	perf.Criteria A
	Surge	IEC/EN61000-4-5	GB/T17626.5	line to line \pm 2KV (1.2 μ s/50 μ s 2Ω) (see Fig. 3 for recommended circuit)	perf.Criteria A

Electromagnetic Compatibility (EMC) (EN50155)

Emissions	CE	EN50121-3-2	150kHz-500kHz	99dBuV	(see Fig. 2 for recommended circuit)
		EN55016-2-1	500kHz-30MHz	93dBuV	(see Fig. 2 for recommended circuit)
Immunity	RE	EN50121-3-2	30MHz-230MHz	40dBuV/m at 10m	(see Fig. 2 for recommended circuit)
		EN55016-2-1	230MHz-1GHz	47dBuV/m at 10m	(see Fig. 2 for recommended circuit)
	ESD	EN50121-3-2	Contact ±6KV/Air ±8KV		perf. Criteria A
	RS	EN50121-3-2	20V/m		perf. Criteria A
	EFT	EN50121-3-2	±2kV 5/50ns	5kHz	(see Fig. 2 for recommended circuit)
	Surge	EN50121-3-2	line to line ±1KV (42Ω, 0.5μF)	(see Fig. 2 for recommended circuit)	perf. Criteria A
	CS	EN50121-3-2	0.15MHz-80MHz	10V r.m.s	perf. Criteria A

Typical Characteristic Curves

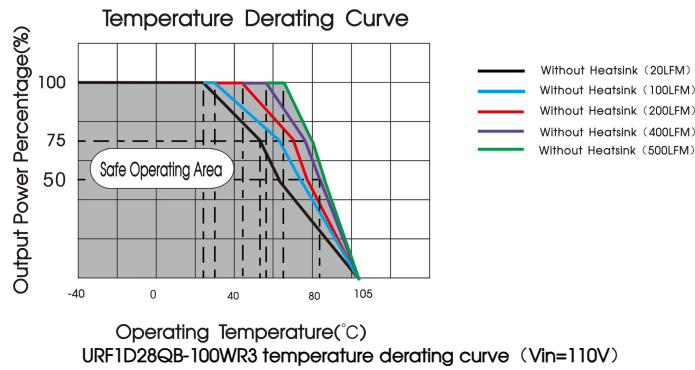

Notes:

1. Temperature derating curves and efficiency curves are typical test values.
2. The temperature derating curve is tested according to our laboratory testing conditions. If the actual environmental conditions used by customers are inconsistent, it is necessary to ensure that the temperature of the aluminum casing of the product does not exceed 100° C, and it can be used within any rated load range.

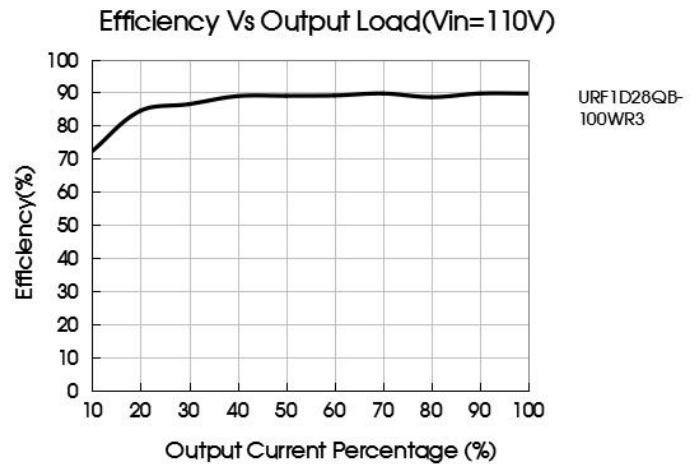
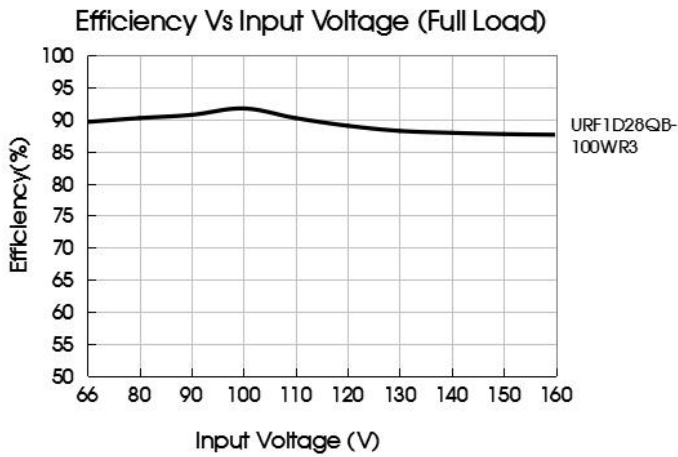

Remote Sense Application

1. Remote Sense Connection if not used

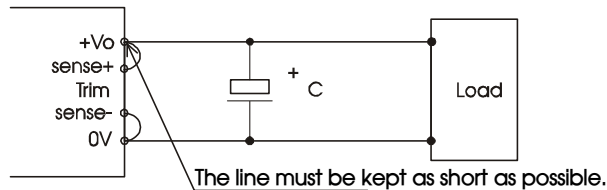

Notes:

- (1) If the sense function is not used for remote regulation the user must connect the +Sense to +Vo and -Sense to 0V at the DC-DC converter pins and will compensate for voltage drop across pins only.

(2) The connections between Sense lines and their respective power lines must be kept as short as possible, otherwise they may be picking up noise, interference and/or causing unstable operation of the power module.

2. Remote Sense Connection used for Compensation

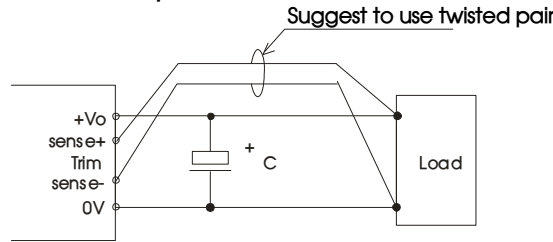

Notes:

- (1) Using remote sense with long wires may cause unstable output, please contact technical support if long wires must be used.
- (2) PCB-tracks or cables/wires for Remote Sense must be kept as short as possible. Twisted pair or shielded wires are suggested for remote compensation and must be kept as short as possible.
- (3) We recommend using adequate cross section for PCB-track layout and/or cables to connect the power supply module to the load in order to keep the voltage drop below 0.3V and to make sure the power supply's output voltage remains within the specified range.
- (4) Note that large wire impedance may cause oscillation of the output voltage and/or increased ripple. Consult technical support or factory for further advice of sense operation.

Design Reference

1. Ripple & Noise

All the DC-DC converters of this series are tested before delivery using the recommended circuit shown in Fig. 1.

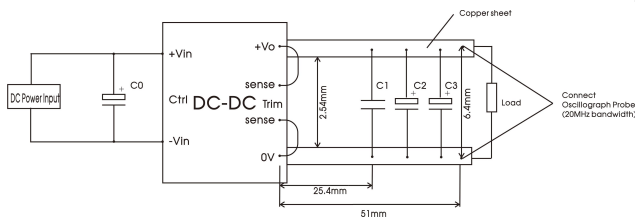

Fig.1

Capacitors value	C0(μF)	C1(μF)	C2(μF)	C3(μF)
Output voltage				
28VDC	100	1	10	220

2. Typical application

We recommended using Mornsun's EMC circuit, otherwise please ensure that at least a 100μF electrolytic capacitors is connected at the input in order to ensure adequate voltage surge suppression and protection.

Input and/or output ripple can be further reduced by appropriately increasing the input & output capacitor values Cin and Cout and/or by selecting capacitors with a low ESR (equivalent series resistance). Also make sure that the capacitance is not exceeding the specified max. capacitive load value of the product.



Capacitors value	Cout(μF)	Cin(μF)
Output voltage		
28VDC	220	100

3. EMC compliance recommended circuit

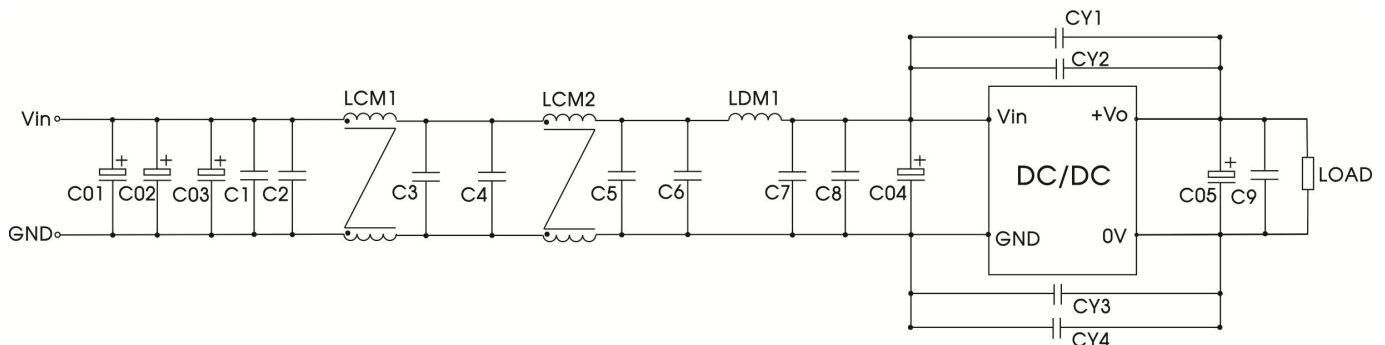

Fig.2

C01, C02, C03, C04	220uF/200V (electrolytic capacitor)
C05	220uF/63V (electrolytic capacitor)
LDM1	1.5uH (Shielded inductor)
C1, C2, C3, C4, C5, C6, C7, C8, C9	2.2uF/250V
CY1, CY2, CY3, CY4	2200 pF /400VAC (Y safety capacitor)
LCM1	Mornsun' FL2D-30-472
LCM2	Mornsun' FL2D-30-102

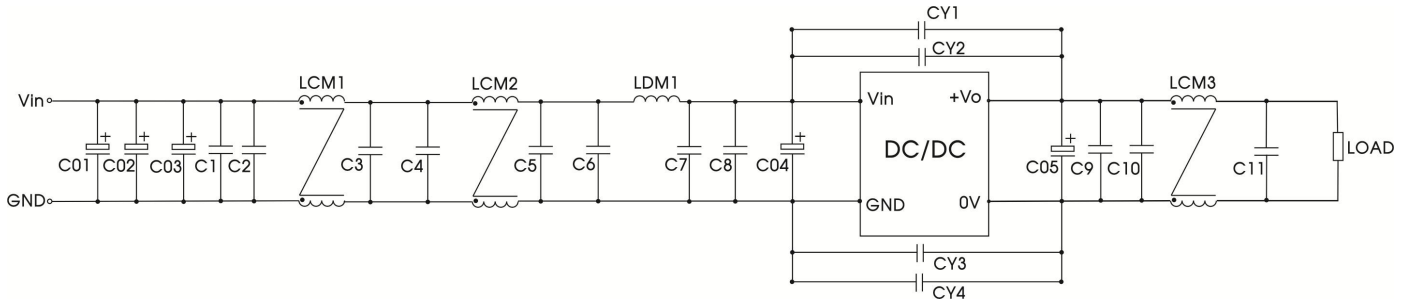
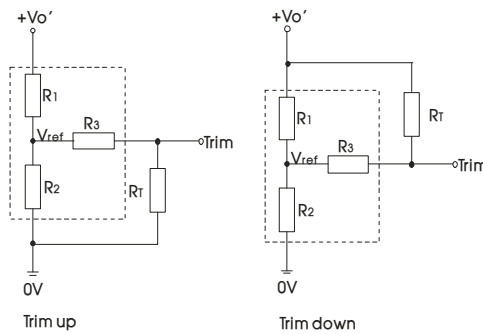

Fig.3

C01, C02, C03, C04	220uF/200V (electrolytic capacitor)
C05	220uF/63V (electrolytic capacitor)
LDM1	1.5uH (Shielded inductor)
C1, C2, C3, C4, C5, C6, C7, C8, C9, C10, C11	2.2uF/250V
CY1, CY2, CY3, CY4	2200 pF /400VAC (Y safety capacitor)
LCM1	Mornsun' FL2D-30-472
LCM2	Mornsun' FL2D-30-102
LCM3	Mornsun' FL2D-70-360C (7A max.)
	Mornsun' FL2D-A3-360C (13A max.)
	Mornsun' FL2D-B5-360C (25A max.)

4. Trim Function for Output Voltage Adjustment (open if unused)



TRIM resistor connection (dashed line shows internal resistor network)

Trim resistor calculation:

$$\begin{aligned} \text{up: } R_T &= \frac{\alpha R_2}{R_2 - \alpha} - R_3 & \alpha &= \frac{V_{ref}}{V_o' - V_{ref}} \cdot R_1 \\ \text{down: } R_T &= \frac{\alpha R_1}{R_1 - \alpha} - R_3 & \alpha &= \frac{V_o' - V_{ref}}{V_{ref}} \cdot R_2 \end{aligned}$$

table 1

Vo resistance	28(VDC)
R1(KΩ)	29.41
R2(KΩ)	2.87
R3(KΩ)	21
Vref(V)	2.5

Note:

For R1, R2, R3 and Vref values refer to table 1. RT = Trim Resistor value; α = self-defined parameter Vo' = desired output voltage

- The products do not support parallel connection of their output
- For additional information please refer to DC-DC converter application notes on www.mornsun-power.com

URF1D28QB-100WR3 Dimensions

THIRD ANGLE PROJECTION

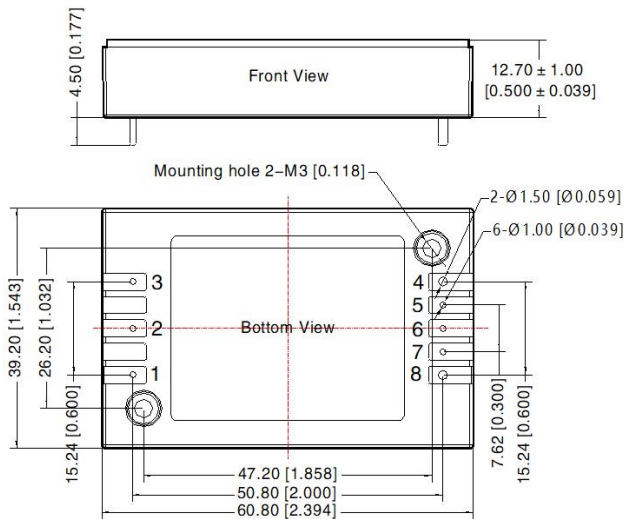

Note:
Unit: mm[inch]
Pin1, 2, 3, 5, 6, 7's diameter: 1.00[0.039]
Pin4, 8's diameter: 1.50[0.059]
Pin diameter tolerances: ± 0.10[± 0.004]
General tolerances: ± 0.50[± 0.020]
Mounting hole screwing torque: Max 0.4 N · m

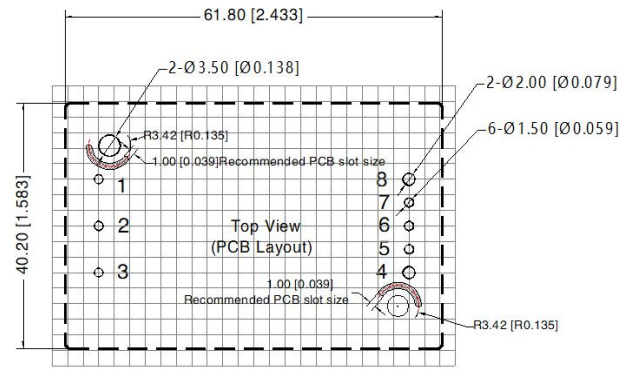

Note: Grid 2.54*2.54mm

Pin-Out			
Pin	Mark	Pin	Mark
1	+Vin	5	Sense-
2	Ctrl	6	Trim
3	-Vin	7	Sense+
4	0V	8	+Vo

- Note:
- For additional information on Product Packaging please refer to www.mornsun-power.com. The Packaging bag number of Horizontal packaging: 58010113;
 - Recommend to use module with more than 5% load, if not, the ripple of the product may exceeds the specification, but does not affect the reliability of the product;
 - The maximum capacitive load offered were tested at input voltage range and full load;
 - It is suggested to take our recommended circuit for EMC testing. If the customer needs to meet the performance of the surge and without taking recommended solution of ours, please make sure the residual voltage of surge less than 180V;
 - It is suggested that customers use enamel film or thermal grease between the heat sink and the module when using the heat sink to ensure good heat dissipation;
 - Unless otherwise specified, data in this datasheet should be tested under the conditions of Ta=25°C, humidity<75%RH with nominal input voltage and rated load;
 - All index testing methods in this datasheet are based on company corporate standards;
 - We provide product customization service and match filter module, please directly contact our technicians for specific information;
 - Products are related to laws and regulations: see "Features" and "EMC";
 - Our products shall be classified according to ISO14001 and related environmental laws and regulations, and shall be handled by qualified units.

Mornsun Guangzhou Science & Technology Co., Ltd.

Address: No. 5, Kehui St. 1, Kehui Development Center, Science Ave., Guangzhou Science City, Huangpu District, Guangzhou, P. R. China
Tel: 86-20-38601850 Fax: 86-20-38601272 E-mail: info@mornsun.cn www.mornsun-power.com