

3W isolated DC-DC converter in SMD Package  
Ultra-wide input and regulated single output

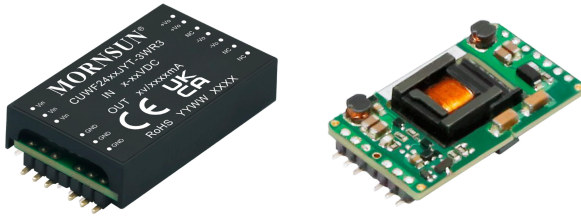

## FEATURES

- Ultra-wide 7:1 input voltage range
- High efficiency up to 80%
- I/O isolation test voltage 3k VAC
- Input under-voltage protection, output short-circuit, over-current, over-voltage protection
- Creepage distance is 4.5mm, clearance is 4.2mm
- Operating ambient temperature range: -40°C to +105°C
- EMI meets automotive standards EN55025/CISPR 25 standard Class 4
- AEC-Q100 standards approved
- Production process meets IATF16949 system

CUWF24\_J(Y)T-3WR3 series are isolated 3W DC-DC converter products with an ultra-wide 7:1 input voltage range. They feature efficiencies up to 80%, input to output isolation is tested with 3000 VAC and the converter safely operate ambient temperature of -40°C to +105°C, input under-voltage protection, output short-circuit, over-current, over-voltage protection. They are widely used in applications such as automobile electronic, industrial control, electric power, instruments and communication fields.

## Selection Guide

Certification	Part No. ①	Input Voltage (VDC)		Output			Full Load Efficiency (%) Min./Typ.	Capacitive Load (μF)Max.
		Nominal (Range)	Max. ②	Voltage(VDC)	Current(mA) Max./Min.			
					6≤Vin<9	9≤Vin≤42		
EN/BS EN	CUWF2405J(Y)T-3WR3	24 (6-42)	45	5	480/0	600/0	74/76	1000
	CUWF2412J(Y)T-3WR3			12	200/0	250/0	76/78	470
	CUWF2415J(Y)T-3WR3			15	160/0	200/0	76/78	220
	CUWF2424J(Y)T-3WR3			24	100/0	125/0	78/80	100

Notes:

- ① CUWF24\_J(Y)T-3WR3 contains 2 types of products, include CUWF24\_JT-3WR3 (SMD package without shell) and CUWF24\_JYT-3WR3 (SMD package with shell);  
② Exceeding the maximum input voltage may cause permanent damage.

## Input Specifications

Item	Operating Conditions	Min.	Typ.	Max.	Unit
Input Current (full load / no-load)	Nominal input voltage	—	165/8	169/15	mA
Reflected Ripple Current		—	30	—	
Surge Voltage (1sec. max.)		-0.7	—	50	VDC
Start-up Voltage		—	—	6	
Input Under-voltage Protection		3.5	4.5	—	
Start-up Time	Nominal input voltage & constant resistance load	—	10	150	ms
Input Filter		Pi filter			
Hot Plug		Unavailable			

## Output Specifications

Item	Operating Conditions	Min.	Typ.	Max.	Unit
Voltage Accuracy ①	5%-100% load	—	±1	±2	%
Linear Regulation	Input voltage variation from low to high at full load	—	±0.2	±0.5	
Load Regulation	5%-100% load	—	±0.5	±1	
Transient Recovery Time	25% load step change, nominal input voltage	—	300	500	μs
Transient Response Deviation	25% load step change, input voltage range	5V output	±4	±8	%
		Others	±3	±5	
Temperature Coefficient	Full load	—	—	±0.03	%/°C

Ripple & Noise <sup>②</sup>	20MHz bandwidth, nominal input voltage, 5%-100% load	--	60	100	mVp-p
Over-voltage Protection	Input voltage range	110	--	160	%Vo
Over-current Protection		110	--	300	%Io
Short-circuit Protection		Continuous, self-recovery			

Note:  
 ①Output voltage accuracy for 0%-5% load is ±3% max;  
 ②Under 0% -5% load conditions, ripple & noise does not exceed 250mV. The "parallel cable" method is used for Ripple and Noise test, please refer to DC-DC Converter Application Notes for specific information.

### General Specifications

Item	Operating Conditions	Min.	Typ.	Max.	Unit
Isolation	Input-output Electric Strength Test for 1 minute with a leakage current of 5mA max.	3000	--	--	VAC
Insulation Resistance	Input-output resistance at 500VDC	1000	--	--	MΩ
Isolation Capacitance	Input-output capacitance at 100kHz/0.1V	--	500	--	pF
Reinforced Isolation	Clearance	4.2	--	--	mm
	Creepage	4.5	--	--	
Operating Temperature	See Fig. 1	-40	--	+105	°C
Storage Temperature		-55	--	+125	
Storage Humidity	Non-condensing	5	--	95	%RH
Pin Soldering Resistance Temperature	Soldering spot is 1.5mm away from case for 10 seconds	--	--	+300	°C
Vibration		GBT 28046.3-2011 4.1.2.4 Random vibration, passenger car, sprung masses (vehicle body) 1. The r.m.s. acceleration value shall be 27.8 m/s <sup>2</sup> . 2. Use a test duration of 8 hours for each plane of the DUT.			
Switching Frequency *	PWM mode	--	270	--	kHz
MTBF	MIL-HDBK-217F@25°C	1000	--	--	k hours
Moisture Sensitivity Level (MSL)	IPC/JEDEC J-STD-020D.1	Level 1			

Note: \*Switching frequency is measured at full load. The module reduces the switching frequency for light load (below 50%) efficiency improvement.

### Mechanical Specifications

Case Material		Black epoxy resin; flame-retardant and heat-resistant (UL94V-0)
Dimensions	CUWF24_JT-3WR3	43.68 x 23.0 x 10.00 mm
	CUWF24_JYT-3WR3	43.68 x 25.0 x 10.64 mm
Weight	CUWF24_JT-3WR3	7.5g (Typ.)
	CUWF24_JYT-3WR3	10.4g (Typ.)
Cooling Method		Free air convection

### Electromagnetic Compatibility (EMC)

Emissions	CE	CISPR25/EN55025 CLASS 4 (see Fig.3 for recommended circuit)		
		CISPR32/EN55032 CLASS A (without external components)		
	RE	CISPR25/EN55025 CLASS 4 (see Fig.3 for recommended circuit)		
		CISPR32/EN55032 CLASS A (without external components)		
Immunity	ESD	ISO10605 Contact ±6kV	perf. Criteria B	
	RS	ISO11452-2 150V/m (see Fig.3 for recommended circuit)	perf. Criteria A	
	BCI	ISO11452-4 1MHz-400MHz,150mA (see Fig.3 for recommended circuit)	perf. Criteria A	
	Electrical transient conduction along supply lines only		ISO7637-2 LEVEL III	
			Pulse1 (see Fig.3 for recommended circuit)	perf. Criteria B
			Pulse2a (see Fig.3 for recommended circuit)	perf. Criteria A
			Pulse2b (see Fig.3 for recommended circuit)	perf. Criteria B
	Pulse3a (see Fig.3 for recommended circuit)	perf. Criteria A		
	Pulse3b (see Fig.3 for recommended circuit)	perf. Criteria A		



CUWF24\_JT-3WR3 Dimensions and Recommended Layout

THIRD ANGLE PROJECTION

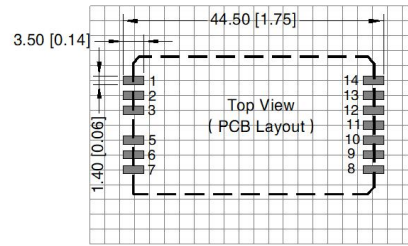
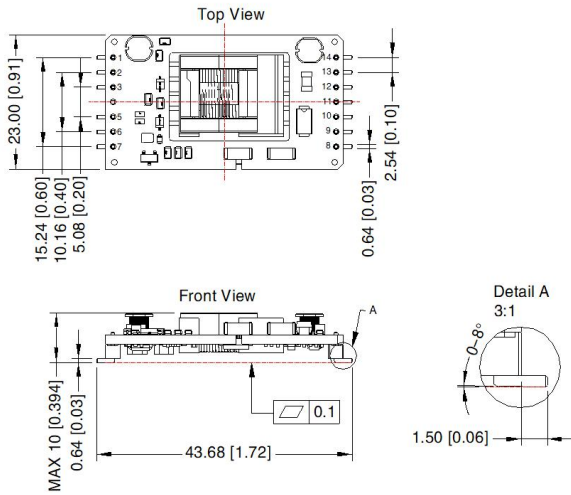

Note: Grid 2.54\*2.54mm

Pin-Out			
Pin	Mark	Pin	Mark
1	Vin	9	NC
2	Vin	10	-Vo
3	Vin	11	-Vo
5	GND	12	NC
6	GND	13	+Vo
7	GND	14	+Vo
8	NC		

NC: Pin to be isolated circuitry

Note:  
Unit: mm[inch]  
Pin diameter tolerances:  $\pm 0.10 [\pm 0.004]$   
General tolerances:  $\pm 0.50 [\pm 0.020]$

CUW24\_JYT-3WR3 Dimensions and Recommended Layout

THIRD ANGLE PROJECTION

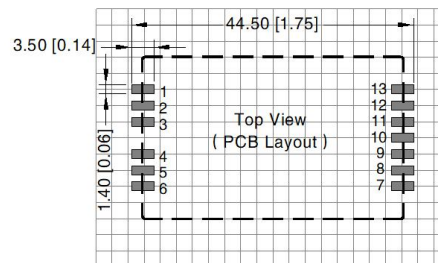
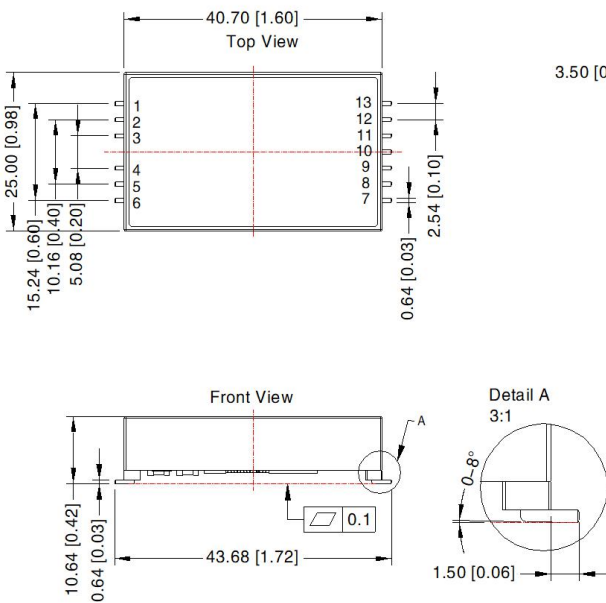

Note: Grid 2.54\*2.54mm

Pin-Out			
Pin	Mark	Pin	Mark
1	Vin	8	NC
2	Vin	9	-Vo
3	Vin	10	-Vo
4	GND	11	NC
5	GND	12	+Vo
6	GND	13	+Vo
7	NC		

NC: Pin to be isolated circuitry

Note:  
Unit: mm[inch]  
Pin diameter tolerances:  $\pm 0.10 [\pm 0.004]$   
General tolerances:  $\pm 0.50 [\pm 0.020]$

Note:

1. For additional information on Product Packaging please refer to [www.mornsun-power.com](http://www.mornsun-power.com). Packaging bag number: 58220085(without shell);58210109(with shell);
2. The maximum capacitive load offered were tested at input voltage range and full load;
3. Unless otherwise specified, parameters in this datasheet were measured under the conditions of  $T_a=25^{\circ}\text{C}$ , humidity<75%RH with nominal input voltage and rated output load;
4. All index testing methods in this datasheet are based on company corporate standards;
5. We can provide product customization service, please contact our technicians directly for specific information;
6. Products are related to laws and regulations: see "Features" and "EMC";
7. Our products shall be classified according to ISO14001 and related environmental laws and regulations, and shall be handled by qualified units.

## Mornsun Guangzhou Science & Technology Co., Ltd.

Address: No. 5, Kehui St. 1, Kehui Development Center, Science Ave., Guangzhou Science City, Huangpu District, Guangzhou, P. R. China  
Tel: 86-20-38601850 Fax: 86-20-38601272 E-mail: [info@mornsun.cn](mailto:info@mornsun.cn) [www.mornsun-power.com](http://www.mornsun-power.com)